

# TEAC<sup>®</sup> AN-180

## NOISE REDUCTION UNIT SERVICE MANUAL

The TEAC AN-180 is a noise reduction unit employing the DOLBY B system. The unit comprises independent playback, record (self-contained microphone amplifier), meter amplifier and oscillator circuits, all utilizing such new solid-state circuit elements as ICs and FETs.

Designed to assure years of trouble-free operation, the unit requires practically no recalibration except after the replacement of components. This manual describes, mainly for the benefit of service engineers, the specifications, adjustment and testing procedures, trouble-shooting and circuit diagrams of the AN-180. Explanations which duplicate those in the instruction manual have been omitted. Please refer to the latter concerning handling and operation.



### TEAC CORPORATION

SALES OFFICE: SHINJUKU BUILDING  
1-8-1, NISHI-SHINJUKU, SHINJUKU, TOKYO  
ROOM NO. 1105  
TEAC HONGKONG LIMITED  
MAIN OFFICE: MELBOURNE PLAZA, 33 QUEEN'S ROAD  
CENTRAL, HONG KONG

U.S. DISTRIBUTOR:

TEAC CORPORATION OF AMERICA  
7733 TELEGRAPH ROAD  
MONTEBELLO, CALIFORNIA 90640  
U.S.A.

EUROPEAN DISTRIBUTOR:

TEAC EUROPE B.V.  
KABELWEG 45-47, AMSTERDAM-W. 2,  
HOLLAND

## SPECIFICATIONS

	SPECIFICATION	DESCRIPTION	CONDITION
OVERALL SECTION:	Frequency Response	20~15kHz $\pm 1.5$ dB	Within Dolby specified INPUT level or less.
	Increased S N Ratio	10kHz 10dB 1kHz 5dB Overall 6dB higher	Weighted
	Input Sensitivity		
	a) Line mic	0.25mV $\pm 2$ dB	
	b) Line input	100mV $\pm 2$ dB	
	c) Line out jack	100mV $\pm 2$ dB	
	Input Impedance		
	a) Line mic	50k $\Omega$ or more	
	b) Line input	100k $\Omega$ or more	
	c) Line out jack	50k $\Omega$ or more	
	Output Level	1V	Load impedance 50k $\Omega$ or more.
	Harmonic Distortion	3% or less	
	Multiplex Filter	19kHz~20dB or more 38kHz~20dB or more 25kHz~3dB $\pm 1$ dB	Switch ON position. Switch OFF position.
Signal to Noise Ratio	65dB or higher		
Channel Separation	50dB or more	INPUT jack 5k $\Omega$	
Oscillator Output Level	100mV $\pm 1$ dB		
Oscillator Frequency	400Hz $\pm 10\%$		
PLAYBACK SECTION:	Frequency Response	(INPUT level -40dB) 10kHz: -10dB $\pm 1$ dB 1kHz: -5dB $\pm 1$ dB 100Hz: 0dB $\pm 1$ dB (INPUT level 0dB) 20~1,500Hz $\pm 1$ dB 100mV $\pm 2$ dB	Measured at level -40dB below specified Input level. Measured at specified Input level.
	INPUT Sensitivity (LINE OUT jack)		
	INPUT Impedance (LINE OUT jack)	50k $\Omega$	
	OUTPUT Level	1V	Load impedance 50k $\Omega$ or more.
	Harmonic Distortion	0.5% or less	
	Multiplex Filter	19kHz: -20dB 38kHz: -20dB 30kHz: 12dB/OCT	Switch ON position. Switch OFF position.

	SPECIFICATION	DESCRIPTION	CONDITION
RECORD SECTION:	Frequency Response	(INPUT level -40dB) 10kHz: +10dB ±1dB 1kHz: +5dB ±1dB 100Hz: 0dB ±1dB (INPUT level 0dB) 20~1,500Hz ±1dB	Measured at level -40dB below specified Input level. Measured at specified Input level.
	INPUT Sensitivity		
	a) Line mic	0.25mV ±2dB	
	b) Line INPUT	100mV ±2dB	
	INPUT Impedance		
	a) Line mic	50kΩ or more	
	b) Line INPUT	100kΩ or more	
	Recording OUTPUT Level	500mV	Load impedance 50kΩ or more.
	Harmonic Distortion	0.3% or less	
	Low Pass Filter	35kHz 18dB/OCT	
	Signal to Noise Ratio	60dB or higher	
POWER:	AC INPUT Voltage	100V (6W) 117V 100/117/220/240V	AN-180 (D) AN-180 (A) AN-180 (F)
	AC INPUT Frequency	50~60Hz	
	AC Outlet	500W(max.)	Power unswitched.
WEIGHT:	7kg net (15-1/2 lbs)		
DIMENSIONS:	140(H) × 410(W) × 325(D)mm		

# BLOCK DIAGRAM

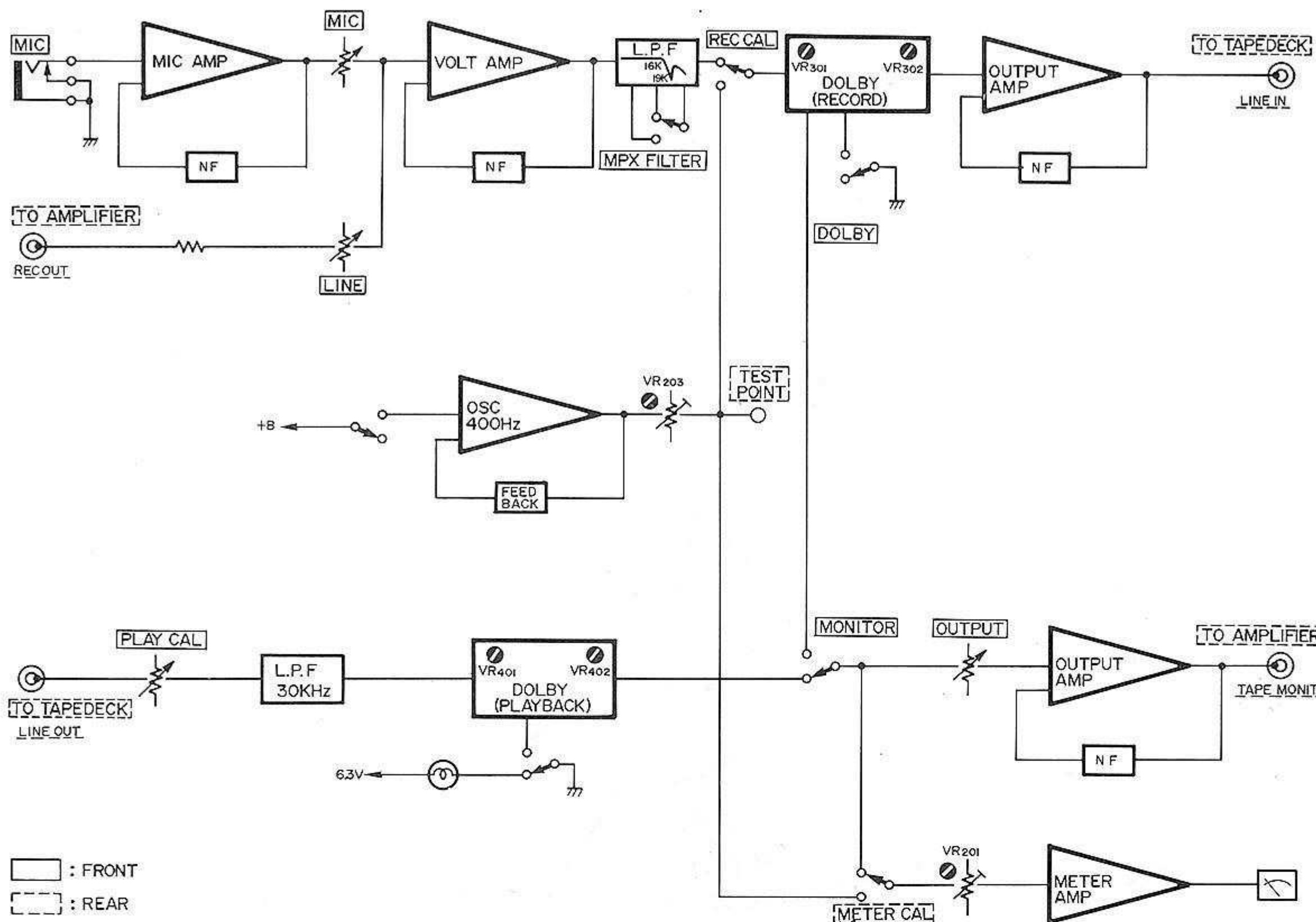

D-0533

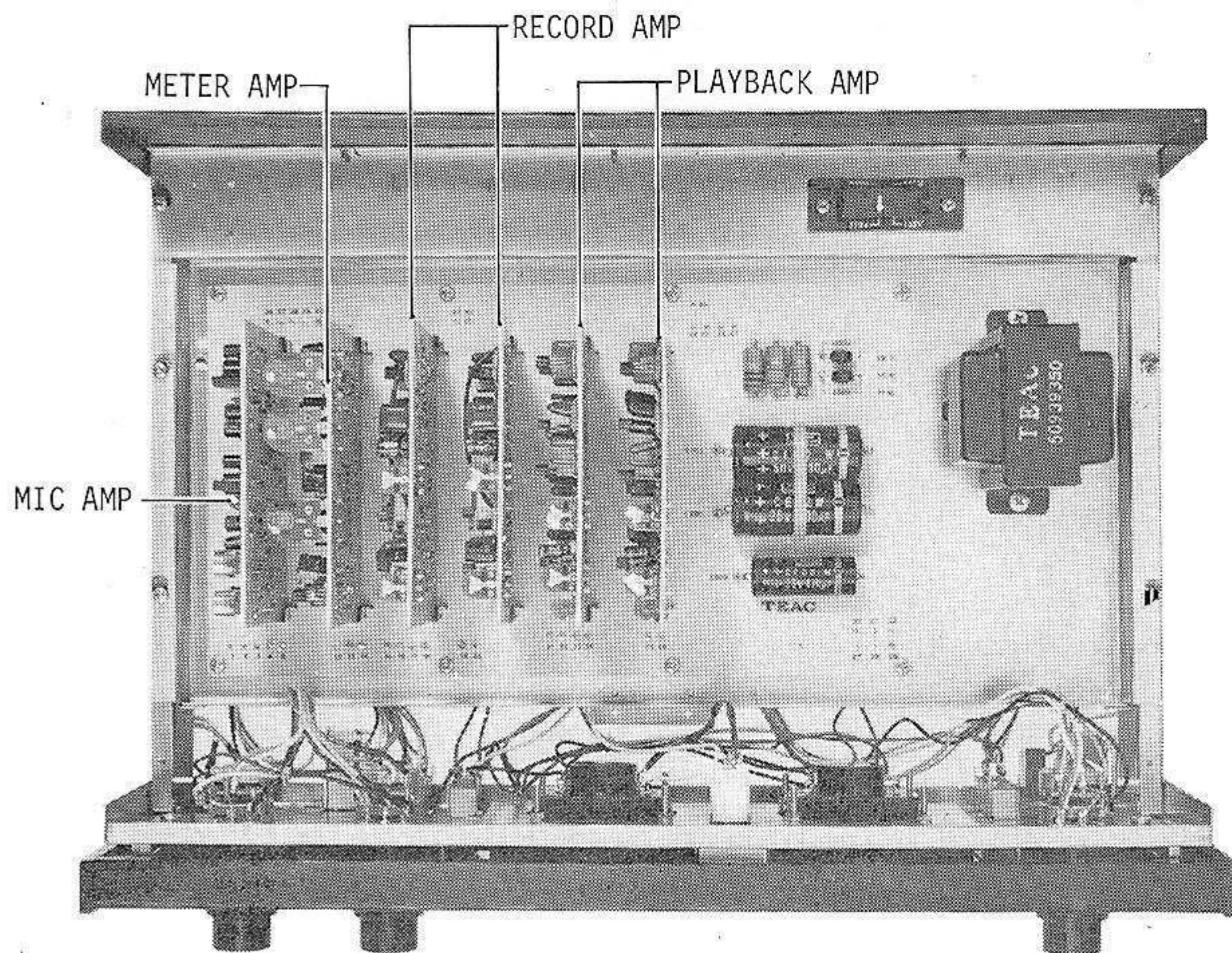

## TESTING PROCEDURE

---

This chapter systematically describes the testing procedures for the playback section, recording section and multiplex filter. Since all these sections interact with each other, pay special heed to the sequence of the testing procedures.

1. Oscillator output level test
2. Level meter sensitivity test
3. Overall characteristics test
4. Playback characteristics test
5. Recording characteristics test
6. Multiplex filter test

When testing the AN-180, use special care to avoid induction hum, not to mention the general precautions you should observe in testing this type of equipment.

When adjusting a semi-fixed variable resistors (particularly of the 10 $\phi$  type), be sure to use a screw driver with an insulated handle (e.g. Part No. 50925740).

After adjustment, secure the semi-fixed variable resistor with white paint.

## REQUIRED TEST EQUIPMENT

---

AF oscillator

AC voltmeter

Input impedance 100k ohm or more

Frequency response 20 to 20,000 Hz or more

Attenuator

Distortion Analyzer

Each test and adjustment should be performed in the sequence shown in the text.

## **1. OSCILLATOR OUTPUT LEVEL TEST**

### a) General

The AN-180 has a built-in oscillator for calibration of the operating level. Check the output level of this oscillator.

### b) Procedure

1. Connect an AC voltmeter between the TEST POINT terminal on the back panel of the AN-180 and the ground.
2. Depress the METER CALIB switch (located on the back panel of the AN-180) and read the indicated value on the AC voltmeter. (100mV  $\pm$ 1 dB)
3. If the reading exceeds permissible limits, adjust VR 203.

## **2. LEVEL METER SENSITIVITY TEST**

### a) General

Using the oscillator adjusted as described above, test the sensitivity of the level meter which is designed for calibration of the operating level of the AN-180.

### b) Procedure

1. With power off, check meter for zero position. If the pointer is not in the zero position, adjust by means of the level meter's zero adjust screw.
2. Apply power to the AN-180 and depress the METER CALIB switch. If the pointer of the level meter does not coincide with the CALIB line, adjust VR 201 and VR 202.

VR 201 ..... Left channel

VR 202 ..... Right channel

#### NOTE

Adjustment of VR 201 and VR 202 may affect the output level of the oscillator. After readjustment of VR 201 and VR 202, therefore, be sure to recheck the output level of the oscillator.

### 3. OVERALL CHARACTERISTICS TEST

#### a) General

To check the characteristics of the AN-180, it is first necessary to measure the overall characteristics. If the measured values do not comply with the specifications, determine whether the cause lies in the record amplifier or in the playback amplifier by means of the procedures described later.

As this point, the overall characteristics measuring procedure is described. Check the positions of the DOLBY switch (ON position) and MONITOR switch (TAPE position).

If the overall frequency response is flat at all frequencies and levels (approximately  $\pm 0.2$  dB or less), recheck the positions of the switches mentioned above. At the same time, note that the trouble may be in both the record and playback amplifiers, although such simultaneous failures rarely occur.

#### b) Connection diagram

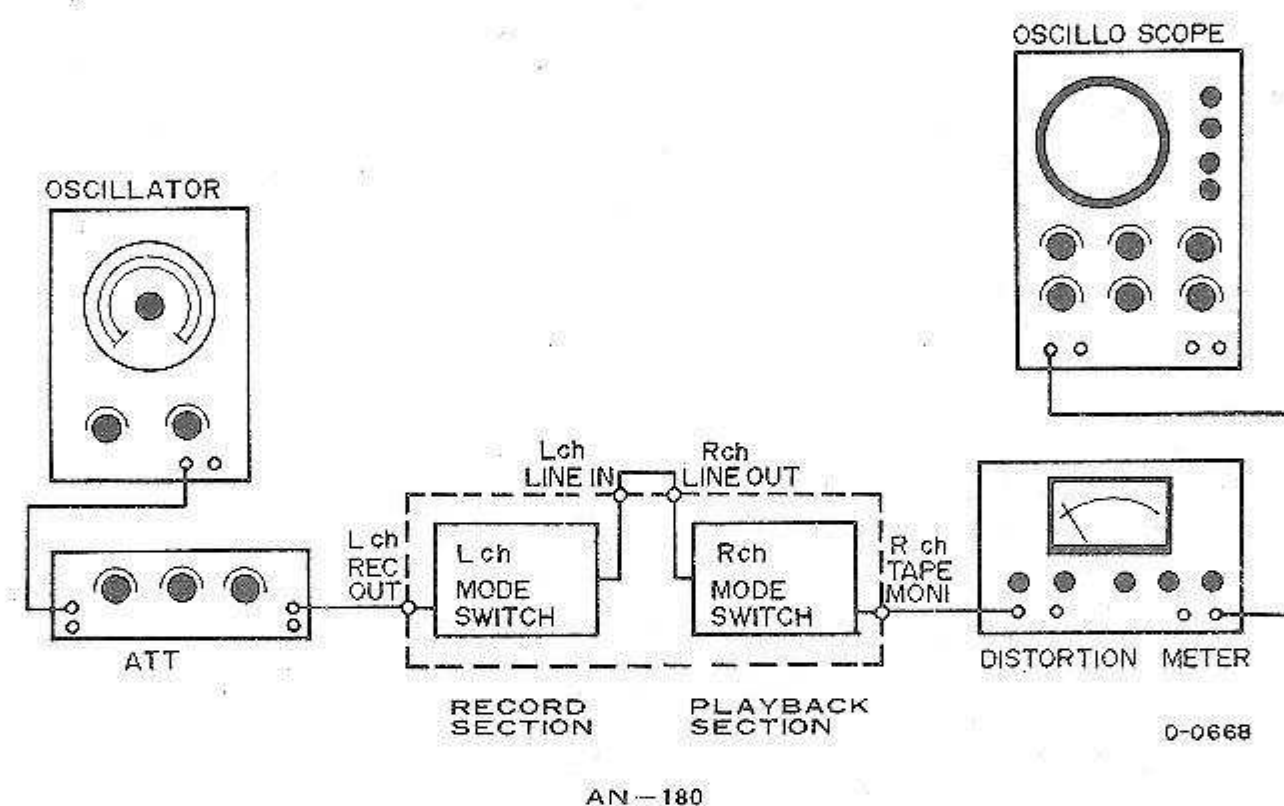

#### NOTE

Short-circuit the LINE IN and LINE OUT terminals of the AN-180 externally by means of a pin cord.

#### c) Calibration

1. Set the MIC variable resistors of the AN-180 in the fully counter-clockwise position.
2. Set the MONITOR switch to SOURCE.
3. Set the oscillator frequency at 100 Hz and output voltage at 0.5V. Insert signal through variable attenuator to REC OUT jacks.
4. Adjust the LINE variable resistor so that the level meter's pointer will coincide with the CALIB line.
5. Set the PLAY CALIB variable resistor of the AN-180 in the fully counter-clockwise position.
6. Set the MONITOR switch to TAPE.
7. Adjust the PLAY CALIB variable resistor so that the level meter's pointer will coincide with the CALIB line.
8. Adjust the OUTPUT variable resistor so that an output voltage of 1V will be supplied at the TAPE MON terminal.

## OVERALL FREQUENCY RESPONSE

---

After making connections as shown in item b) and performing calibration as in item c), measure the frequency response at each input level.

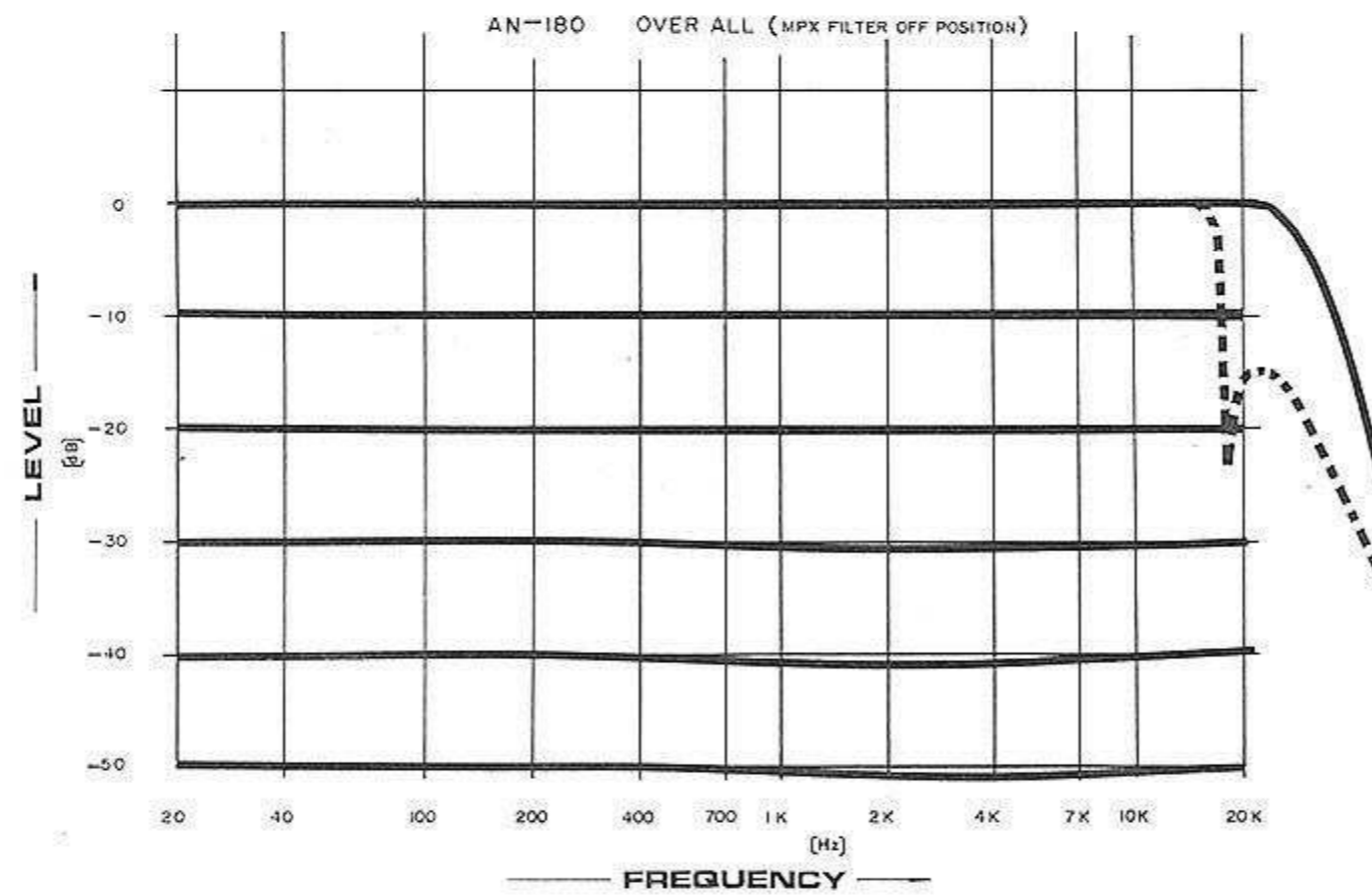

## OVERALL HARMONIC DISTORTION FACTOR

---

Following the overall frequency response check, measure the overall harmonic distortion factor by means of a harmonic distortion factor meter. The characteristics specification shows the value of distortion factor at 1V output voltage and 1 kHz frequency.

## OVERALL SIGNAL TO NOISE RATIO

---

After making connections as in foregoing item b) and performing calibration as in item c), measure the overall S/N ratio with the REC OUT terminal shorted.



## 4. PRAYBACK CHARACTERISTICS TEST

### a) Connection diagram

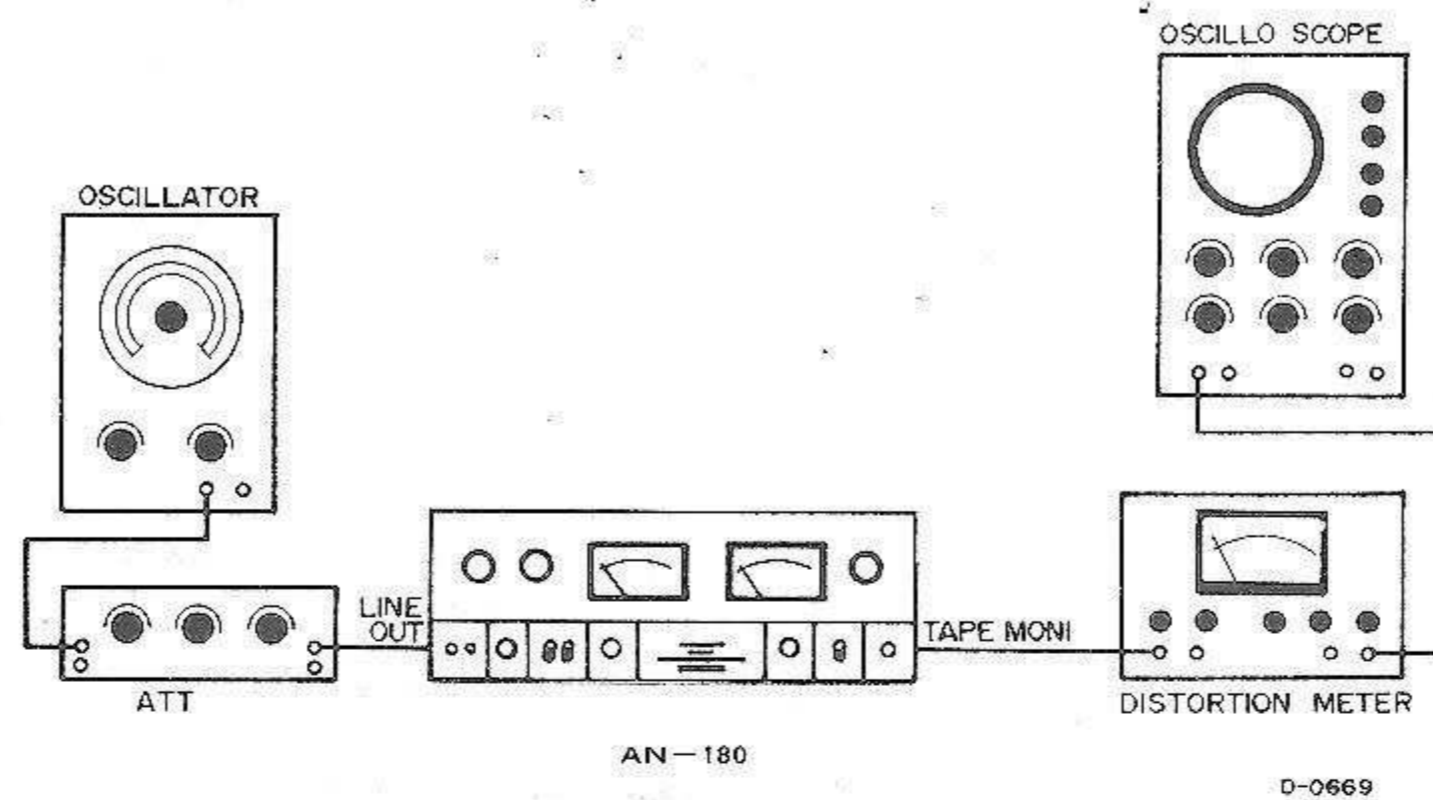

### b) Calibration

1. Set the PLAY CALIB variable resistor of the AN-180 in the fully counter-clockwise position.
2. Set the MONITOR switch to TAPE.
3. Set the oscillator frequency at 100 Hz and output voltage at approx. 0.5V.
4. Adjust the PLAY CALIB variable resistor so that the pointer of the AN-180 level meter will coincide with the CALIB line.
5. Adjust the OUTPUT variable resistor so that an output voltage of 1V will be supplied at the TAPE MON terminal. The voltmeter reading at this point should be 0 dB.

### PLAYBACK FREQUENCY RESPONSE

After making connections as in the diagram a) and performing calibration as in the foregoing item b), measure the playback frequency response at each input level. (See the drawing below.)

If the measured response deviates from the specified response, readjust using the procedures outlined in section c).

Before attempting readjustment, take every possible step to eliminate measuring and instrument errors. The ATT and AC voltmeter in particular should be calibrated to their true values.

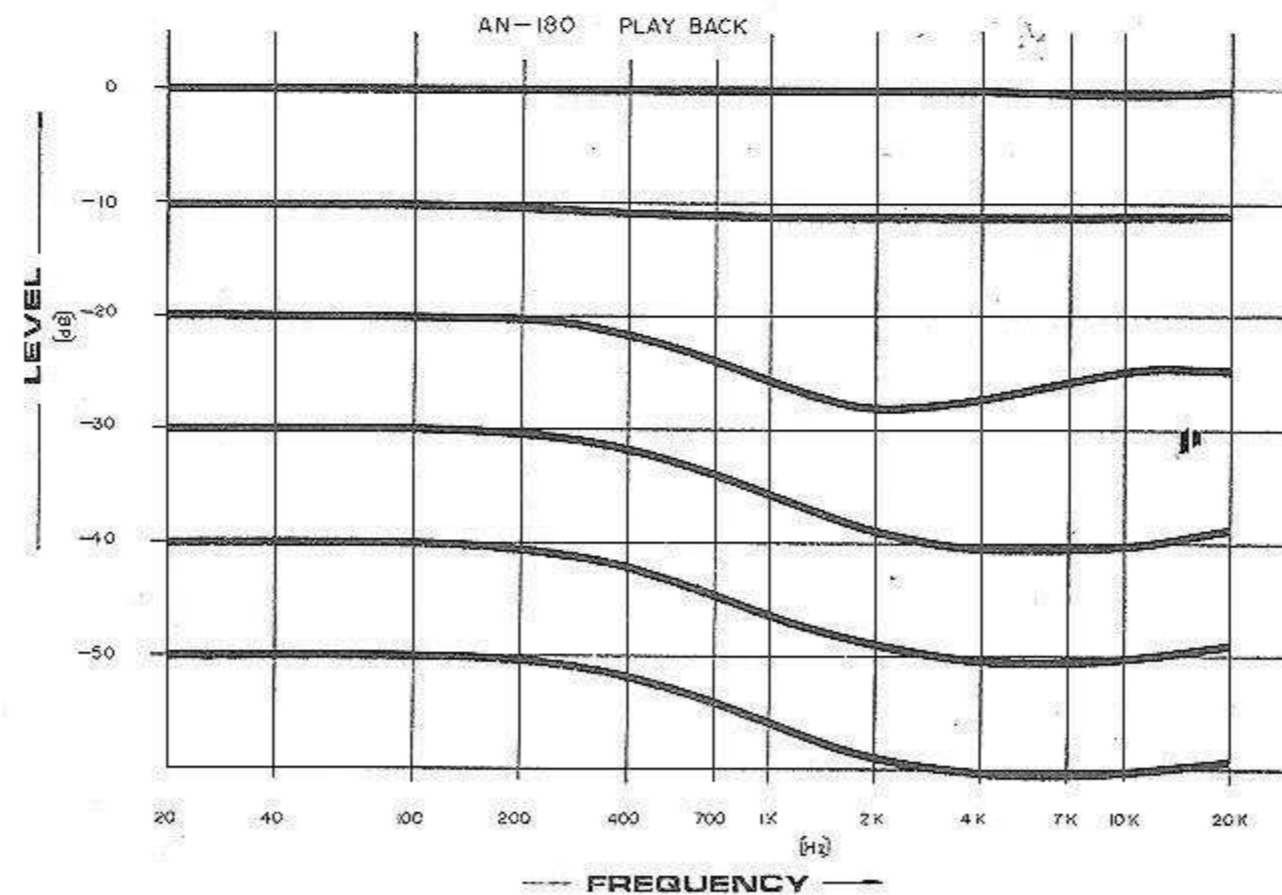

# ADJUSTMENT OF INPUT/OUTPUT CHARACTERISTICS OF PLAYBACK AMPLIFIER

## a) General

The AN-180 varies its input/output characteristics in accordance with the input signal as it produces a record signal. The playback amplifier has characteristics opposite those of the record mode to restore the signal to its original state.

These change characteristics must be made identical at the respective settings. Procedures for adjusting the input/output characteristics of the playback section follow;

## b) Connection diagram

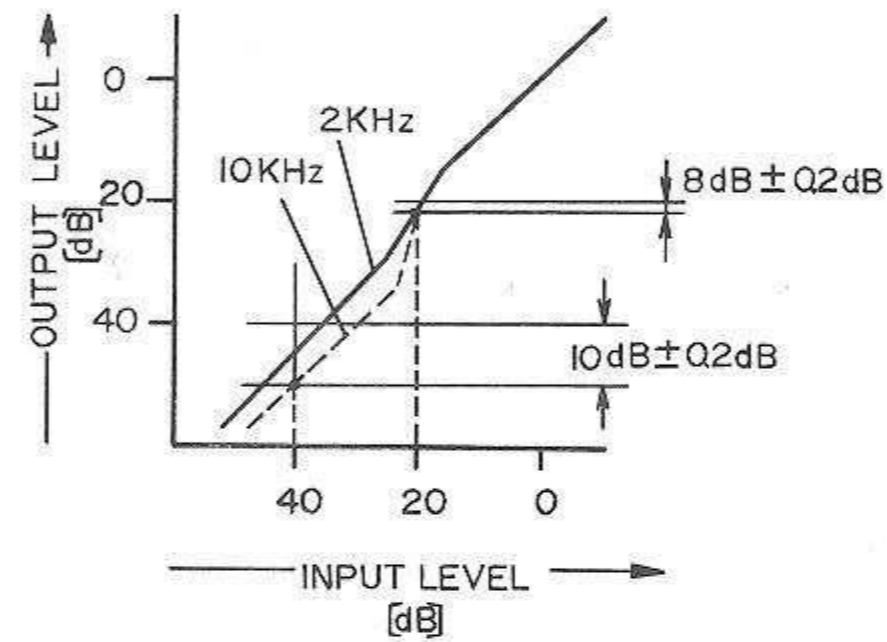
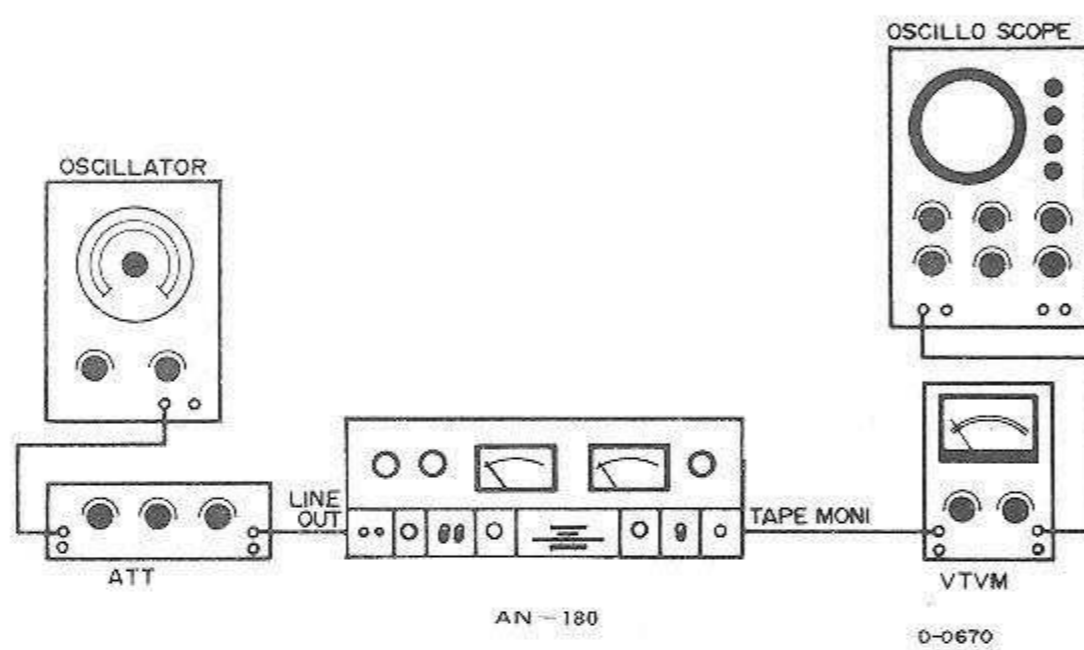

## c) Procedure

1. Carry out calibration in accordance with steps 1 through 6 of the Overall Characteristics Test.
2. Change the oscillator frequency to 2 kHz and set the ATT at -20 dB.
3. Set VR 402 in the fully counter-clockwise position.
4. Adjust VR 401 so that the pointer of the AC voltmeter indicates -28 dB  $\pm$  0.2 dB.
5. Change the oscillator frequency to 10 kHz and set the ATT at -40 dB.
6. Adjust VR 402 so that the pointer of the AC voltmeter indicates -50 dB.
7. Again change the oscillator frequency to 2 kHz and set the ATT at -20 dB.
8. Adjust VR 401 so that the pointer of the AC voltmeter indicates -28 dB  $\pm$  0 dB.

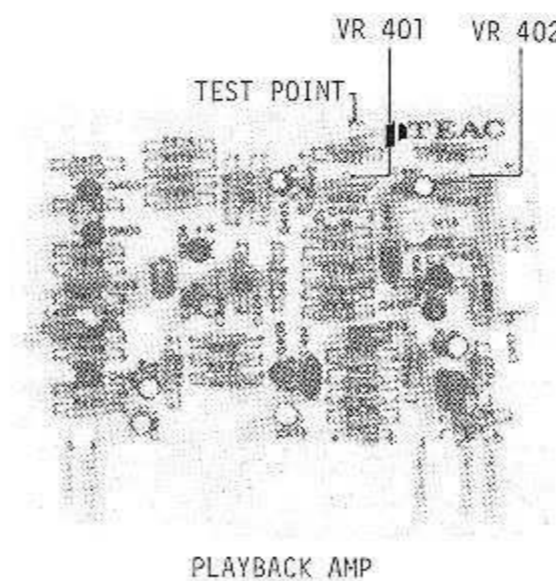
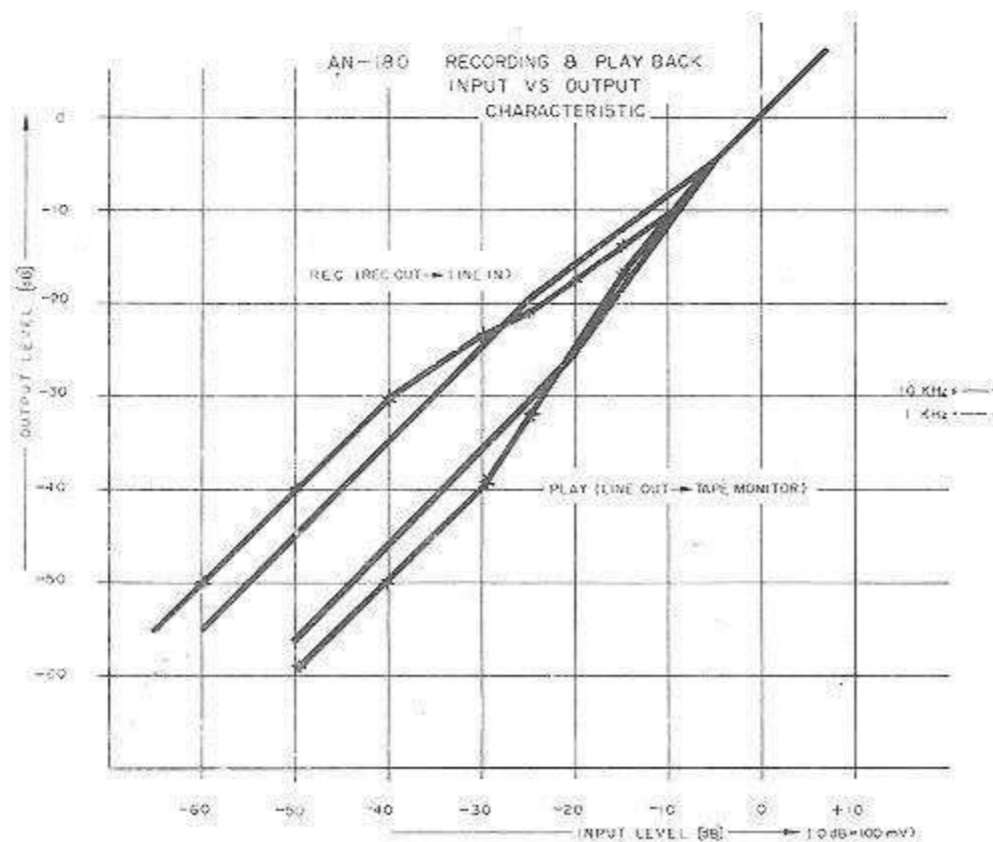

PLAYBACK SECTION HARMONIC DISTORTION FACTOR \_\_\_\_\_

After making connections as in the foregoing item a) and performing calibration as in the foregoing item b), measure the playback section harmonic distortion factor by means of a harmonic distortion factor meter.

The specification chart shows the value of distortion factor at 1V output voltage and 1 kHz frequency, 0.5% or less.

PLAYBACK SECTION SIGNAL TO NOISE RATIO \_\_\_\_\_

With equipment connected as shown above, measure the playback section S/N ratio with the LINE OUT terminal shorted.

## 5. RECORD CHARACTERISTICS TEST

### a) Connection diagram

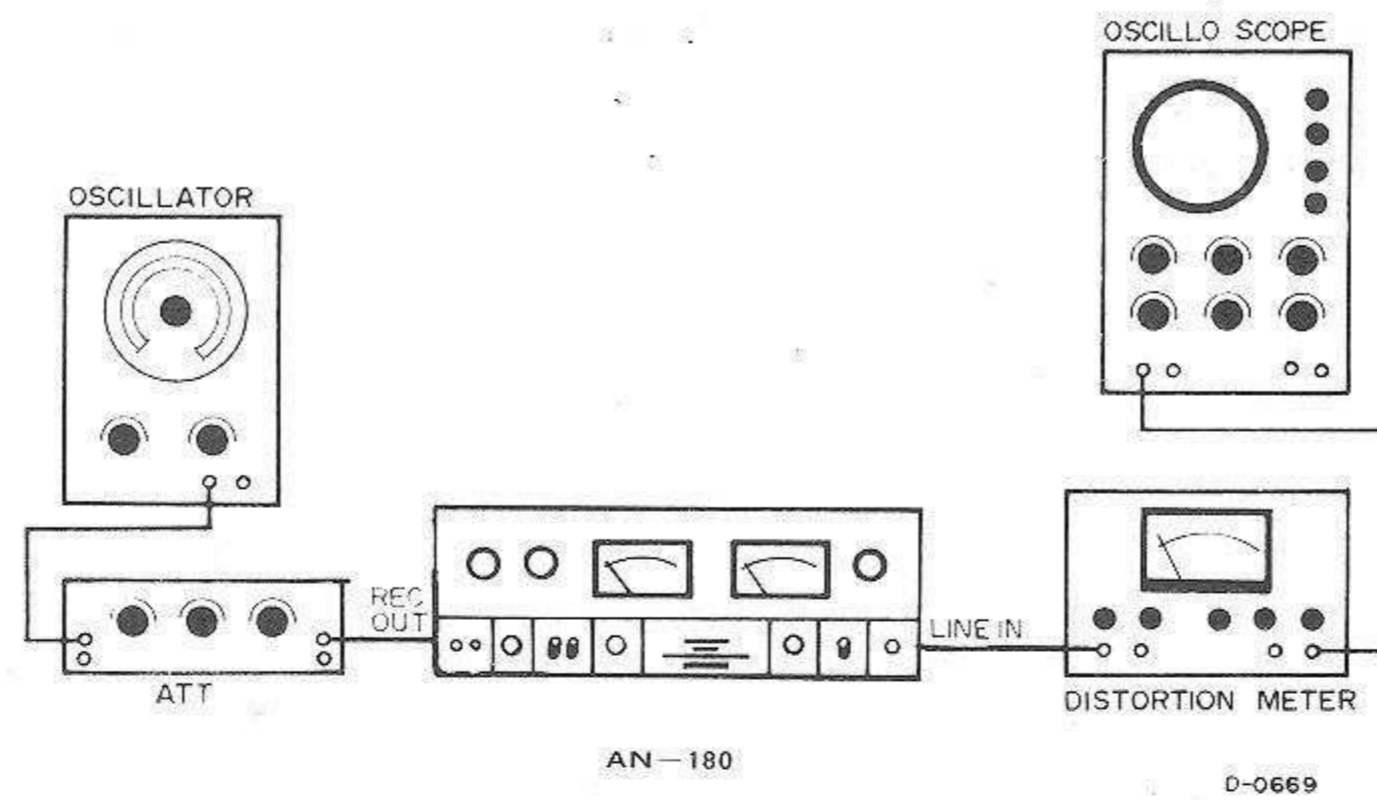

### b) Calibration

1. Set the MIC variable resistor of the AN-180 in the fully counter-clockwise position.
2. Set the MONITOR switch to SOURCE.
3. Set the oscillator frequency at 100 Hz and output voltage at 0.5V.
4. Adjust the LINE variable resistor so that the pointer of the AN-180 level meter will coincide with the CALIB line.

### RECORD FREQUENCY RESPONSE

After making connections as in the foregoing item a) and performing calibration as in the foregoing item b), measure the frequency response at each input level (see the drawing below).

If the measured response deviates from the specified response, re-adjust using the procedures outlined under "Adjustment of input/output characteristics of record amplifier".

Before attempting readjustment, take every possible step to eliminate measuring and instrument errors. The ATT and AC voltmeter in particular should be calibrated to their true values.

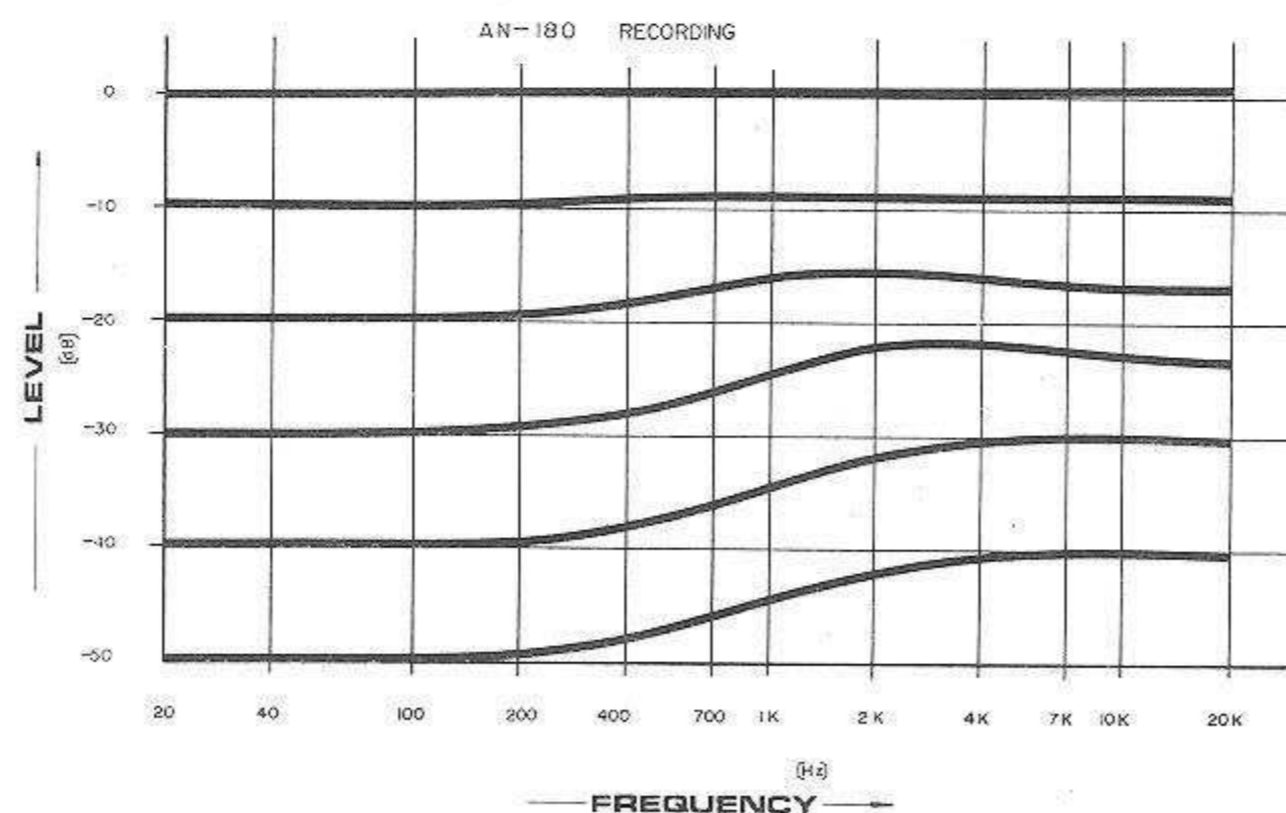

# AN-180 BLOCK DIAGRAM

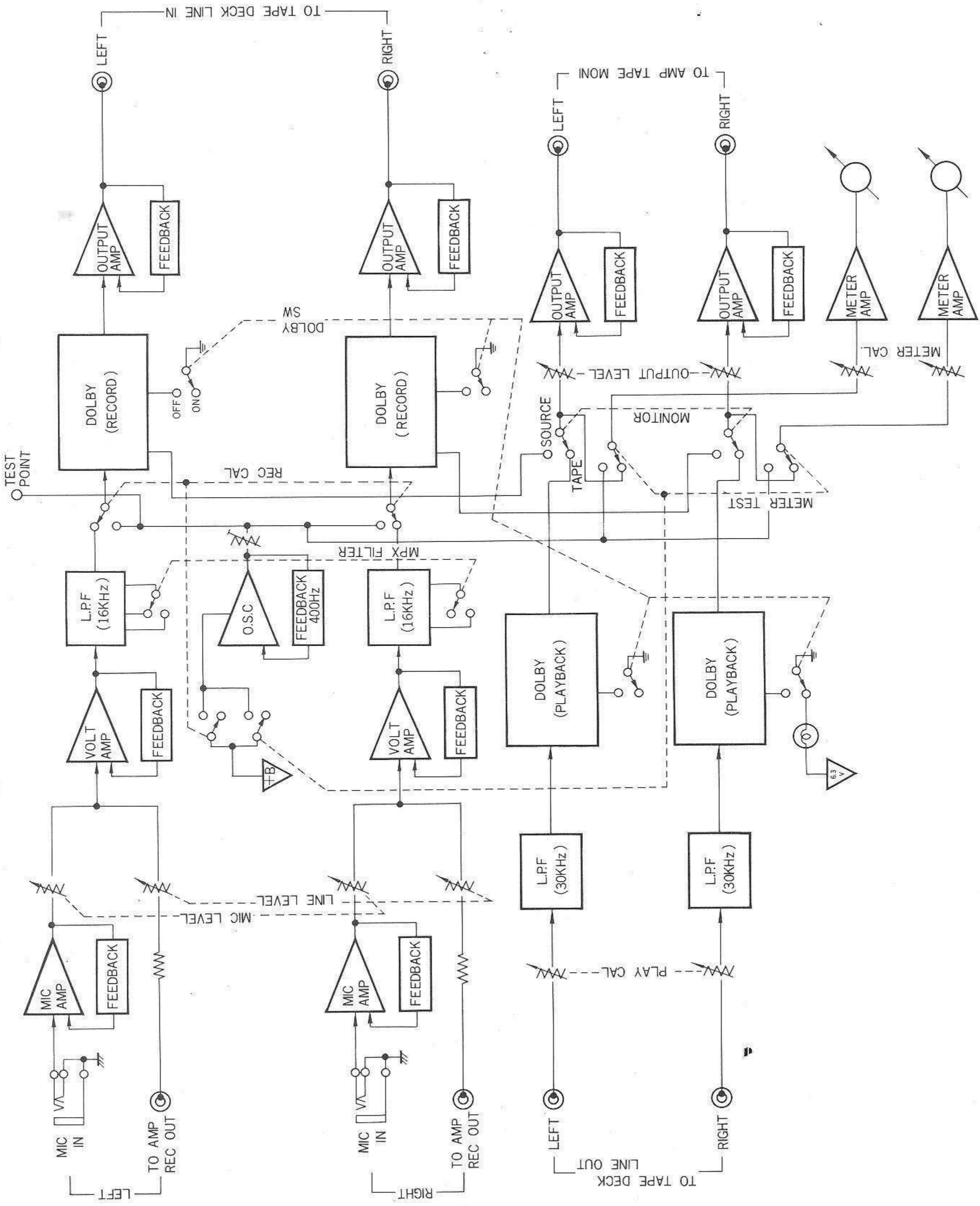

RECORD/HARMONIC DISTORTION FACTOR \_\_\_\_\_

With test equipment connected as shown above, measure the record section harmonic distortion factor by means of a harmonic distortion factor meter.

The specification chart shows the value of distortion factor at 0.5V output voltage and 1 kHz frequency, 0.3% or less.

RECORD SECTION S/N RATIO \_\_\_\_\_

With equipment connected as shown above, measure the record section S/N ratio with the REC OUT terminal shorted.

## ADJUSTMENT OF INPUT/OUTPUT CHARACTERISTICS OF RECORD AMPLIFIER

### a) General

Adjust the input/output characteristics of the record amplifier, in line with adjustment of the playback amplifier as outlined in the section on playback characteristics test, so that the overall input/output characteristics will be linear at any frequency.

### b) Connection diagram

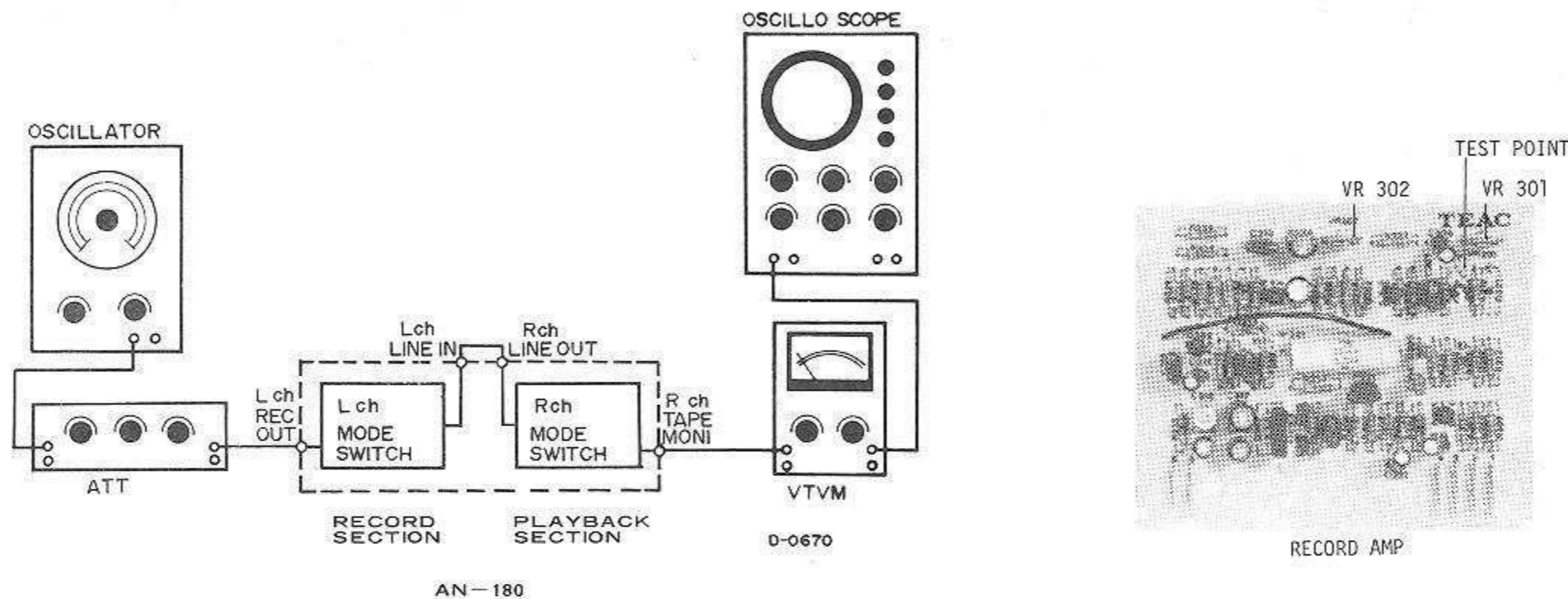

### c) Procedure

1. Set the PLAY CALIB variable resistor and MIC variable resistor of the AN-180 in the fully counter-clockwise positions.
2. Connect the LINE IN and LINE OUT terminals of the AN-180.
3. Set the MONITOR switch to SOURCE.
4. Apply a 100 Hz 0.5V signal from the oscillator to the REC OUT terminal.
5. Adjust the LINE variable resistor so that the level meter's pointer will coincide with the CALIB line.
6. Set the MONITOR switch to TAPE.
7. Adjust the PLAY CALIB variable resistor so that the level meter's pointer coincides with the CALIB line.
8. Connect the AC voltmeter to the TAPE MONITOR terminal.  
At this point, the AC voltmeter reading should be 0 dB.
9. Change the oscillator frequency to 2 kHz and set the ATT at -20 dB.
10. Set VR 302 of the AN-180 to the fully clockwise position.
11. Adjust VR 301 so that the AC voltmeter indicates -20 dB.
12. Change the oscillator frequency to 10 kHz and set the ATT at -40 dB.
13. Adjust VR 302 so that the AC voltmeter indicates -40 dB.
14. Again change the oscillator frequency to 2 kHz and set the ATT at -20 dB.

## 6. MULTIPLEX FILTER TEST

To prevent sub-carrier interference when using an FM multiplex tuner as a program source, the AN-180 incorporates a multiplex filter circuit. Procedures for testing this filter are outlined below.

### a) Connection Diagram

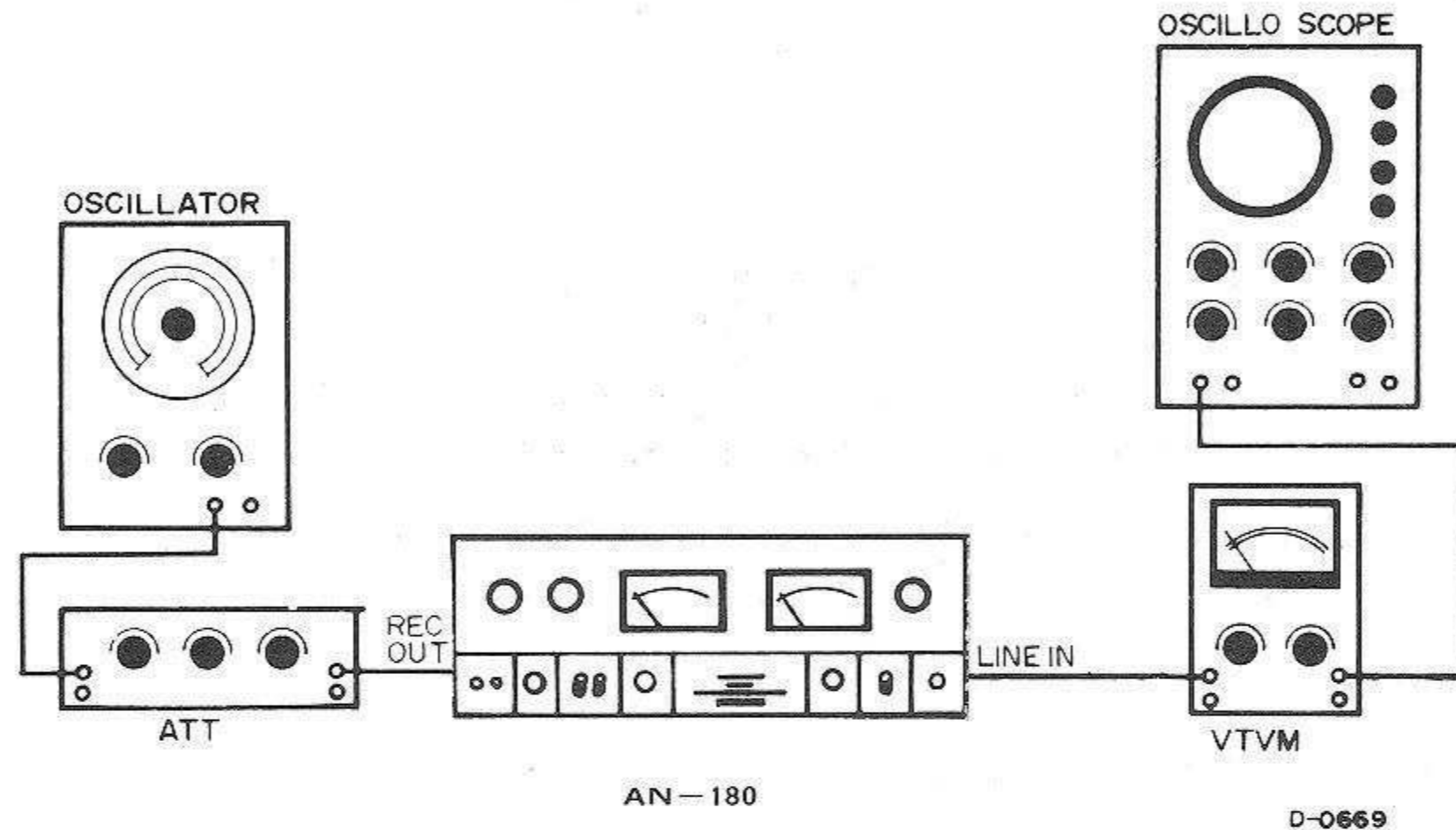

### b) Procedure

1. Set the MONITOR switch of the AN-180 to SOURCE.
2. Set the MPX filter switch to OFF.
3. Set the oscillator frequency at 1 kHz and output voltage at 0.5V.
4. Adjust the LINE variable resistor so that the pointer of the AN-180 level meter will coincide with the CALIB line.
5. Connect the AC voltmeter to the LINE IN terminal of the AN-180. At this point, the AC voltmeter reading should be 0 dB.
6. Set the oscillator frequency at 30 kHz.
7. Adjust L 101 and L 102 so that the pointer of the AC voltmeter will indicate -3 dB.

L 101 ..... Left channel

L 102 ..... Right channel

8. Set the MPX filter switch to ON.
9. Set the oscillator frequency at 19 kHz.
10. Adjust L 103 and L 104 so that the AC voltmeter will present a minimum indication.

L 103 ..... Left channel

L 104 ..... Right channel

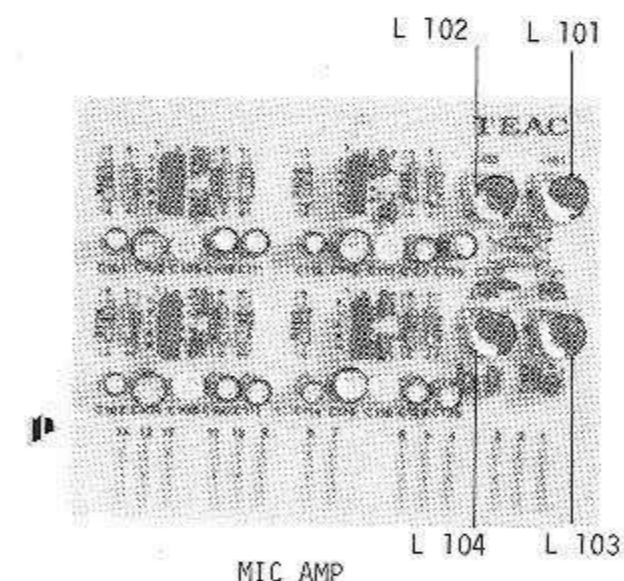

11. After the adjustments, secure L 101, L 102, L 103 and L 104 with white paint.



## 7. TROUBLE SHOOTING

The AN-180 Noise Reduction Unit employs conventional solid state circuitry and is designed to provide extended trouble free operation if operated in accordance with the operating instructions.

The following difficulties may occur as a result of improper calibration or operating procedures and do not represent equipment malfunctions.

Hum occurs when AN-180 is turned on.

Microphone amplifier gain is set at max. with no microphone connected.

Retard Microphone volume when not recording from microphones.

Tape is started, no source sound at monitor jack.

AN-180 monitor switch is in Tape position.

Monitor switch must be in Source position to monitor source recording signal.

Meter does not indicate at Calib. line when calib. switch is depressed.

Calibration tolerance is  $\pm 1.5$  dB at room temperature. Slight variations from calib. line are normal with varying temperatures.

REC CALIB and Meter CALIB switches do not lock.

These are spring loaded switches and are not designed to remain depressed for extended periods of time.

Loss of high frequencies when playing tapes.

DOLBY switch is at IN position, tape is non Dolby processed.

If non-Dolby tapes are played back through the AN-180 with the Dolby switch at IN position a noticeable loss of high frequencies will occur. No benefits are derived in this case, no noise reduction is achieved unless the tape is recorded and played back through the AN-180, therefore when playing non-Dolby processed tapes the DOLBY switch should always be in the OUT position.

If Dolby processed tapes are to be played back on a non-Dolby system, the high frequencies (Treble) will be brighter than normal, this may be compensated for by reducing the treble response at the amplifier tone controls.

Sound is abnormal when using Dolby process.

If the AN-180 is properly calibrated to your tape deck, no change in frequency response will occur. The Dolby system does not limit or affect overall frequency response. Only the inherent tape noise and hiss are affected. The complete absence of hiss and noise may cause you to feel that some high frequencies have been lost, such is not the case.

However if the play or record calibrations are improperly accomplished a degradation of sound quality will result. Since the record/playback expansion/compression levels must be exactly opposite to achieve maximum noise reduction, proper calibration and operating procedures are of paramount importance.

If sound quality seems poor or abnormal, recheck the calibration adjustments as outlined in the operators manual.

The following are malfunctions that may occur as a result of component failure.

Symptom-AN-180 records normally through Line inputs but microphone inputs are inoperative.

Probable cause: Defective transistor, Q 101 or Q 102 or associated components of PC board assy #50939020. Dirty or tarnished contacts on PC board connector.

Symptom-VU meter indications are sluggish although the AN-180 operates normally.

Probable cause: Defective transistor, Q 201 or Q 202 or associated components of meter amplifier PC board assembly #50939040.

Variable resistors VR 201/202 improperly adjusted. See adjustments section of manual. If VR 201/202 are readjusted, check the oscillator output at the test point on rear panel of AN-180. If necessary adjust the oscillator output in accordance with the instructions in the adjustment section of the manual.

Dirty or tarnished contacts on PC board connector.

Symptom-REC CALIB oscillator output is incorrect.

VR 203 improperly adjusted.

Symptom-REC CALIB oscillator output is incorrect and will not adjust to proper level.

Probable cause: Defective transistor, Q 205, Q 206, Q 207 or associated components of PC board assy #50939040.

Dirty or tarnished contacts on PC board connector.

Symptom-No sound at playback, level meters deflect, volume at maximum.

Probable cause: Defective transistor, Q 203 or Q 204 of meter amplifier PC board assy #50939040 or associated components.

Symptom-at playback tape deck meters deflect, AN-180 meters do not move and no sound is heard.

Probable cause: Defective transistor, Q 401, Q 402, Q 403, Q 404 or associated components of playback amplifier PC board assy #50939080.

Dirty or tarnished contacts on PC board connector.

Symptom-Tape deck will not record, AN-180 VU meters deflect but no signal is present at tape deck.

Probable causes: Three head tape decks, check setting of tape deck monitor switch, must be in source position.

If VU meters of tape deck deflect but recording does not occur, tape deck is defective.

If VU meters of tape deck do not move even with monitor switch in source position,

Defective transistor Q 305 or associated circuitry of recording amplifier PC board assembly #50939070.

Dirty or tarnished PC board connector contacts.

Symptom-Tape deck will not record, AN-180 VU meters do not deflect.

Probable cause: Defective transistors, Q 103 or Q 104 or associated components of PC board assembly #50939020.

Defective transistor Q 301 or associated circuitry of record amplifier assembly #50939070.

Symptom-Sound quality is poor or unusual, high frequencies are brighter than normal.

Place Dolby switch of AN-180 to OUT position.

Dolby switch does not affect sound quality → tape deck is at fault.

If sound quality returns to normal

Inject a 10 kHz signal to the input of the playback amplifier PC board assembly and monitor to see if input signal are being compressed normally.

→ If operation appears normal

↓  
Improper operating techniques are at fault

→ If playback amplifier is not operating properly

↓  
Insert a 10 kHz signal at 0.5V at the AN-180 LINE OUT jacks. Connect a VTVM between the playback amplifier test point and ground, indicated voltage value at test point should be approximately 1V.

→ If indication is nearly correct

Adjust VR 401/402 in accordance with the instructions in adjustment section of manual.

→ If no voltage is present at test point probable cause is;

↓  
Defective transistor Q 404, Q 405, Q 406, Q 407, Q 408 or associated circuitry of playback amplifier PC board assembly #50939090.

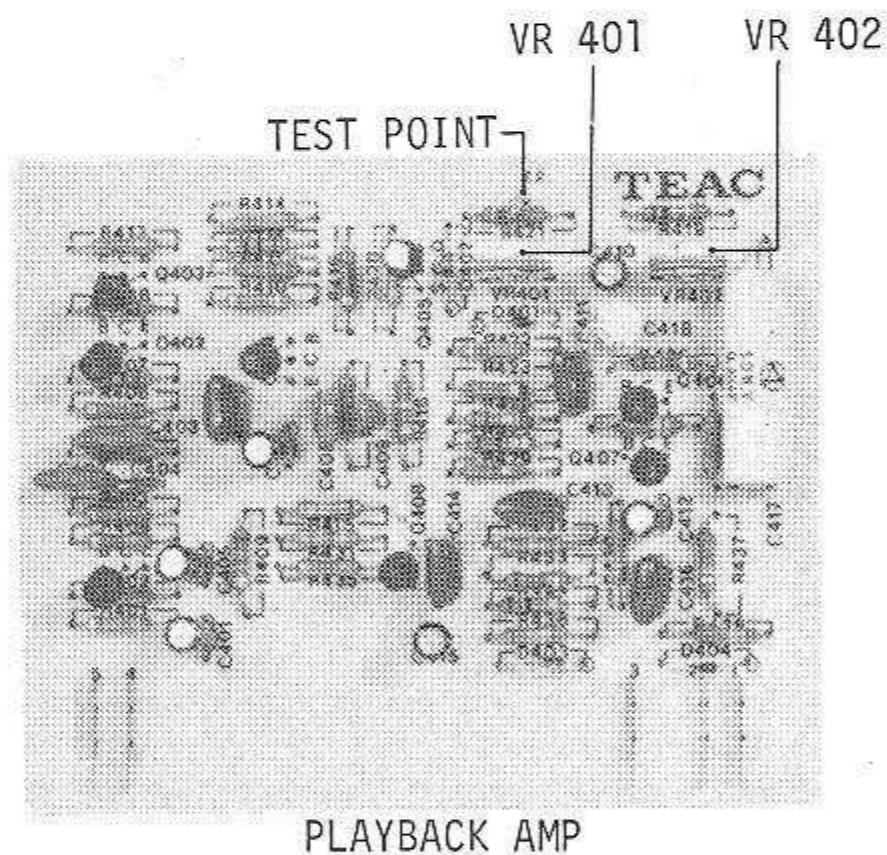

#### NOTE

After locating and replacing defective components perform the appropriate adjustments as outlined in the adjustment section of this manual.

Symptom Sound quality is poor, high frequencies are attenuated or weak.

Place AN-180 Dolby switch to OUT position.

Sound quality remains unchanged → problem is in tape deck.

If sound quality returns to normal

Inject a 10 kHz signal to the input of the record amplifier PC board assy and monitor to see if input signals are being expanded normally.

→ If operation appears normal

↓  
Improper operating techniques are at fault.

→ If record amplifier is not operating properly

↓  
Place AN-180 Monitor switch at Source position. Apply a 10 kHz 0.5V signal at REC OUT jacks of AN-180. Adjust Line volume until VU meter needles indicate at CALIB line. Connect a VTVM from Record amplifier test point to ground. Indicated reading should be approximately 1V.

→ If indication is nearly correct

↓  
Adjust VR 301/302, see adjustment section of manual for complete procedures.

→ If no voltage is present at test point, probable cause.

↓  
Defective transistor Q 302, Q 303, Q 304, Q 306 or associated components of Record amplifier PC board assembly #50939070.

↓  
After locating and replacing defective components perform the appropriate adjustments as outlined in the adjustment section of this manual.

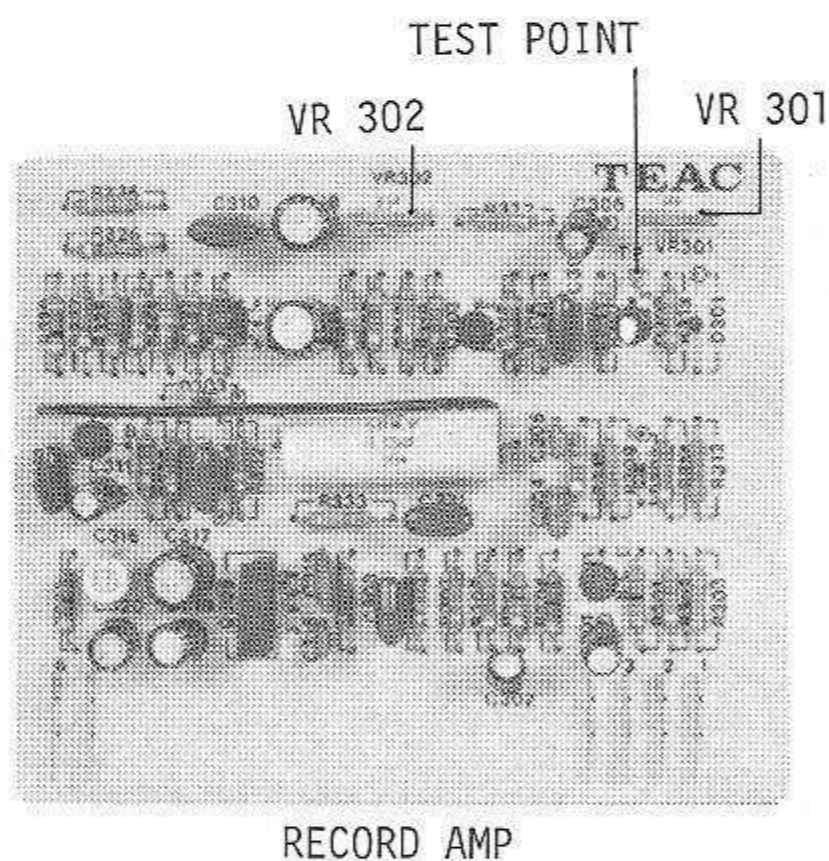

#### NOTE

If repairs are accomplished in either the record or playback PC board assemblies both must be readjusted as per the adjustments section of this manual. The same is true if either assembly is changed as a unit.

## REPLACEMENT OF FET'S USED IN DOLBY SYSTEM

The FET's used in the DOLBY system have been standardized to two types, 2SK-30DA(part No.57240780) and 2SK30-DB(part No.57240990). As a result, the frequency response is more uniform and becomes easier to adjust.

The assemblies using these FET's are also of two kinds. They must be discriminatively used. For actual replacement, proceed as follows.

---

AN-180

---

The two record amplifier PC board assemblies and two playback amplifier PC board assemblies, must use the same type of FET's (2SK30-DA for example) throughout.

When a defective FET used in one of the four PC board assemblies is to be replaced, be sure to use a replacement FET of the same type used in the other three assemblies. If the FET's you have on hand are different from the type of the FET replaced, you must replace the three FET's of the other assemblies with the same type.

The same applies to the replacement of an assembly. The part Nos. of these assemblies are as follows.

### Record Amplifier PC Board Assemblies

Those using 2SK30-DA...50939510 (used with playback amplifier assy 50939520)

Those using 2SK30-DB...50939530 (used with playback amplifier assy 50939540)

### Playback Amplifier PC Board Assemblies

Those using 2SK30-DA...50939520 (used with record amplifier assy 50939510)

Those using 2SK30-DB...50939540 (used with record amplifier assy 50939530)



D-0699

**SCHEMATIC DIAGRAMS  
AND  
PRINTED CIRCUIT BOARD**



# PLAYBACK AMPLIFIER

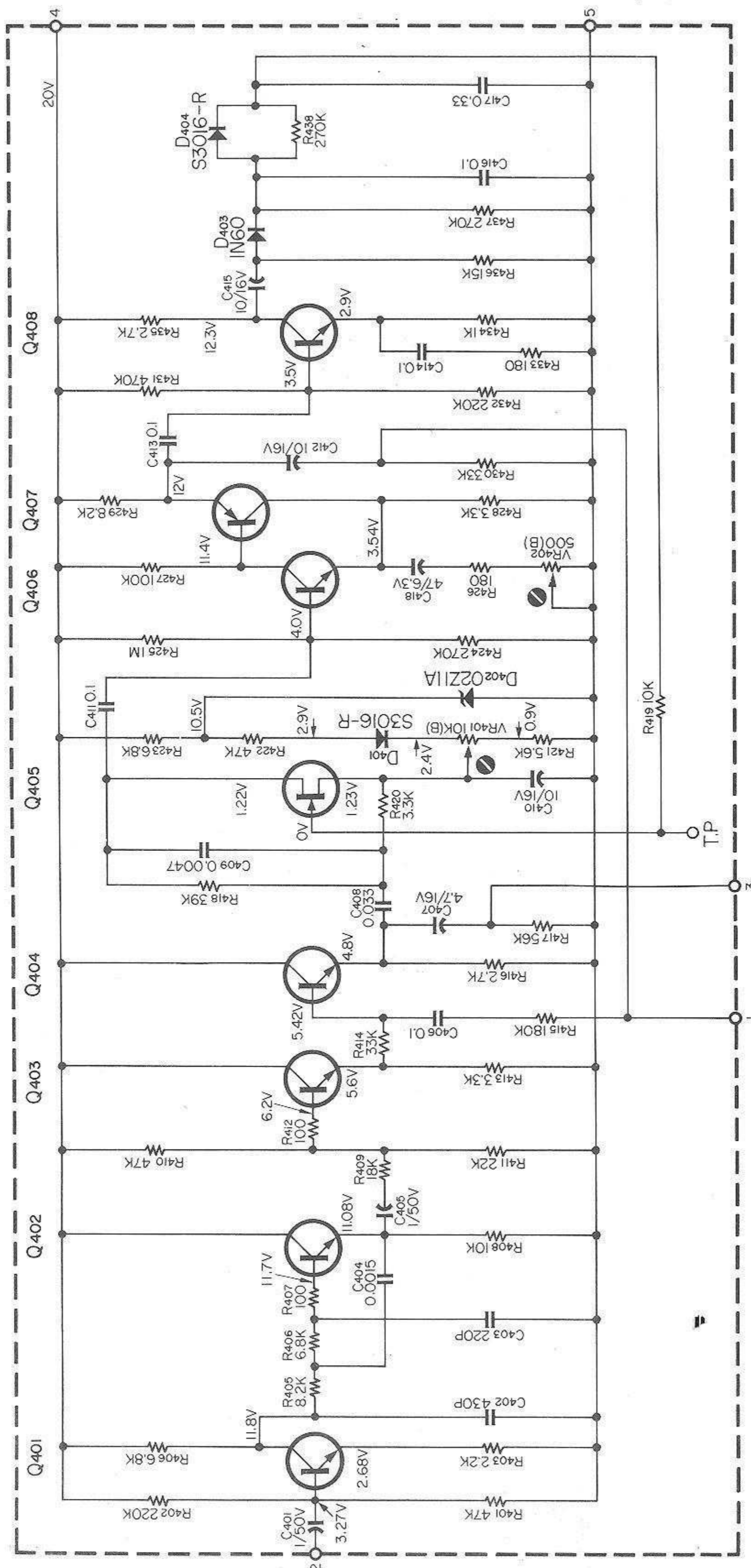

N-0460

CIRCUIT REF. NO.	DESCRIPTION
Q401-402-403	2SC733-Y
Q404-406-408	2SK30-Y
Q405	2SA562-Y
Q407	2SA562-Y

# PLAYBACK AMPLIFIER

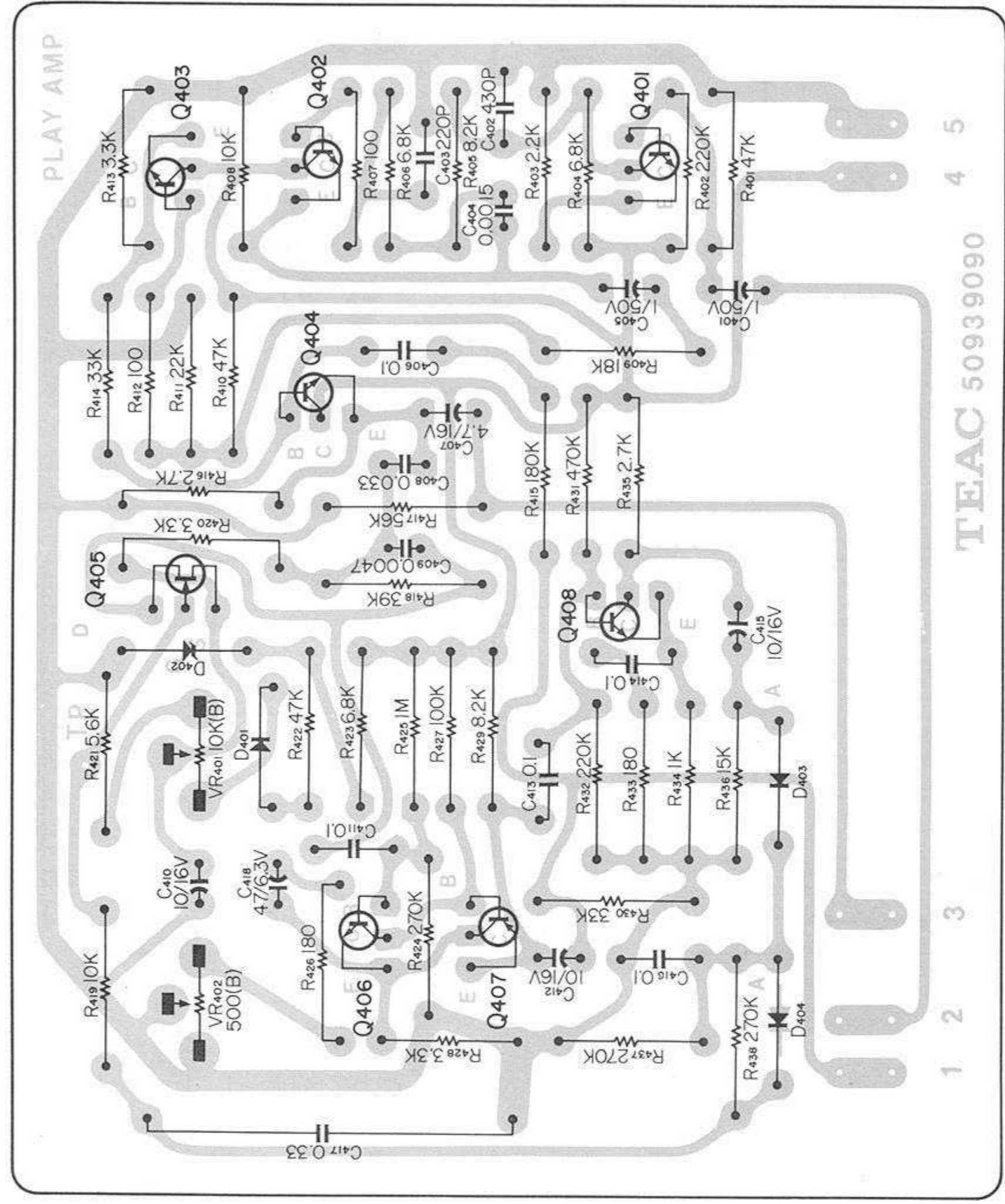

# METER, OUTPUT, OSC ASSY

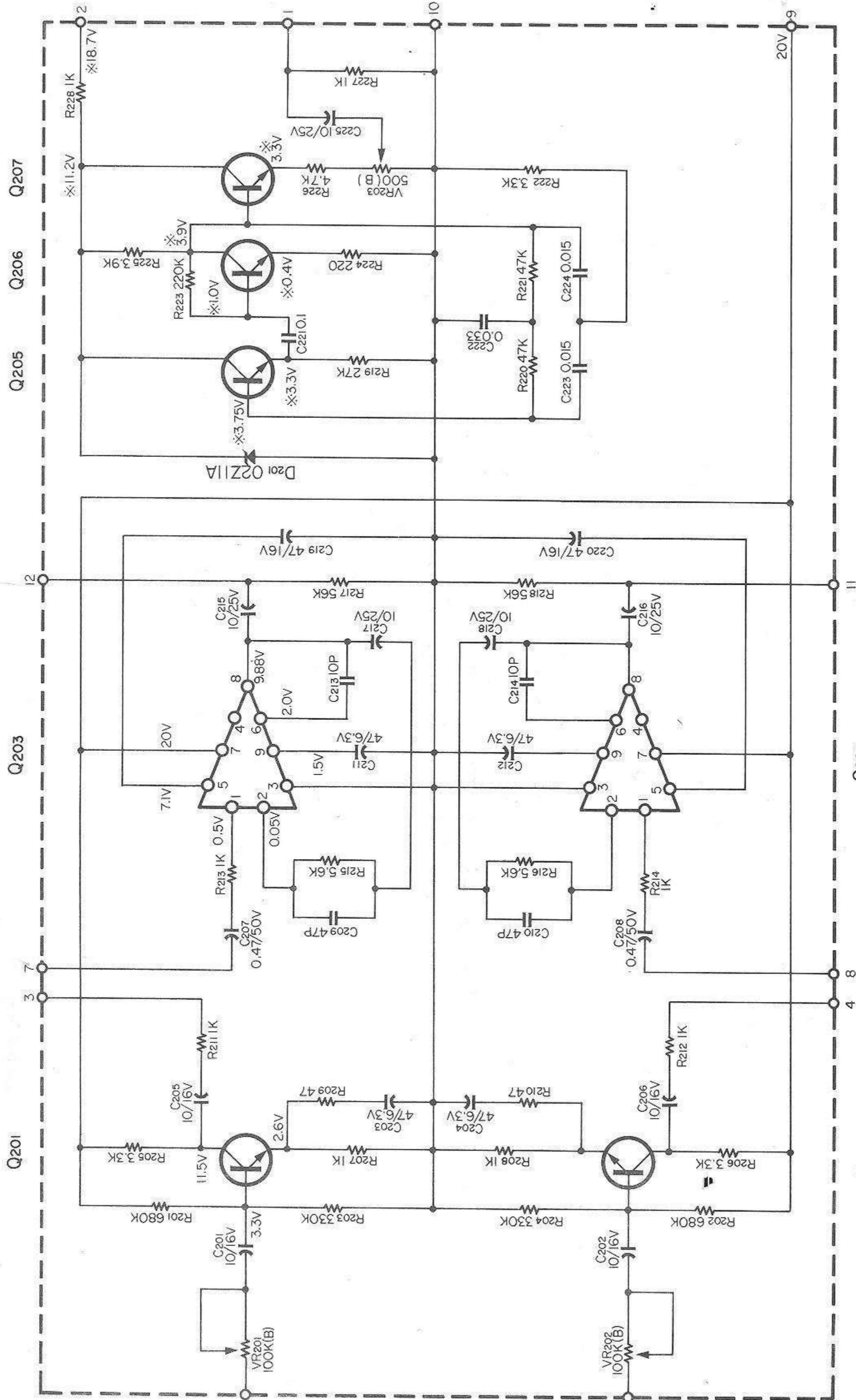

CIRCUIT REF. NO.	DESCRIPTION
Q201/Q202 • Q205 • Q206 • Q207	2SC733-Y
Q203/Q204	IC 42709

N-0458

# METER, OUTPUT, OSC ASSY

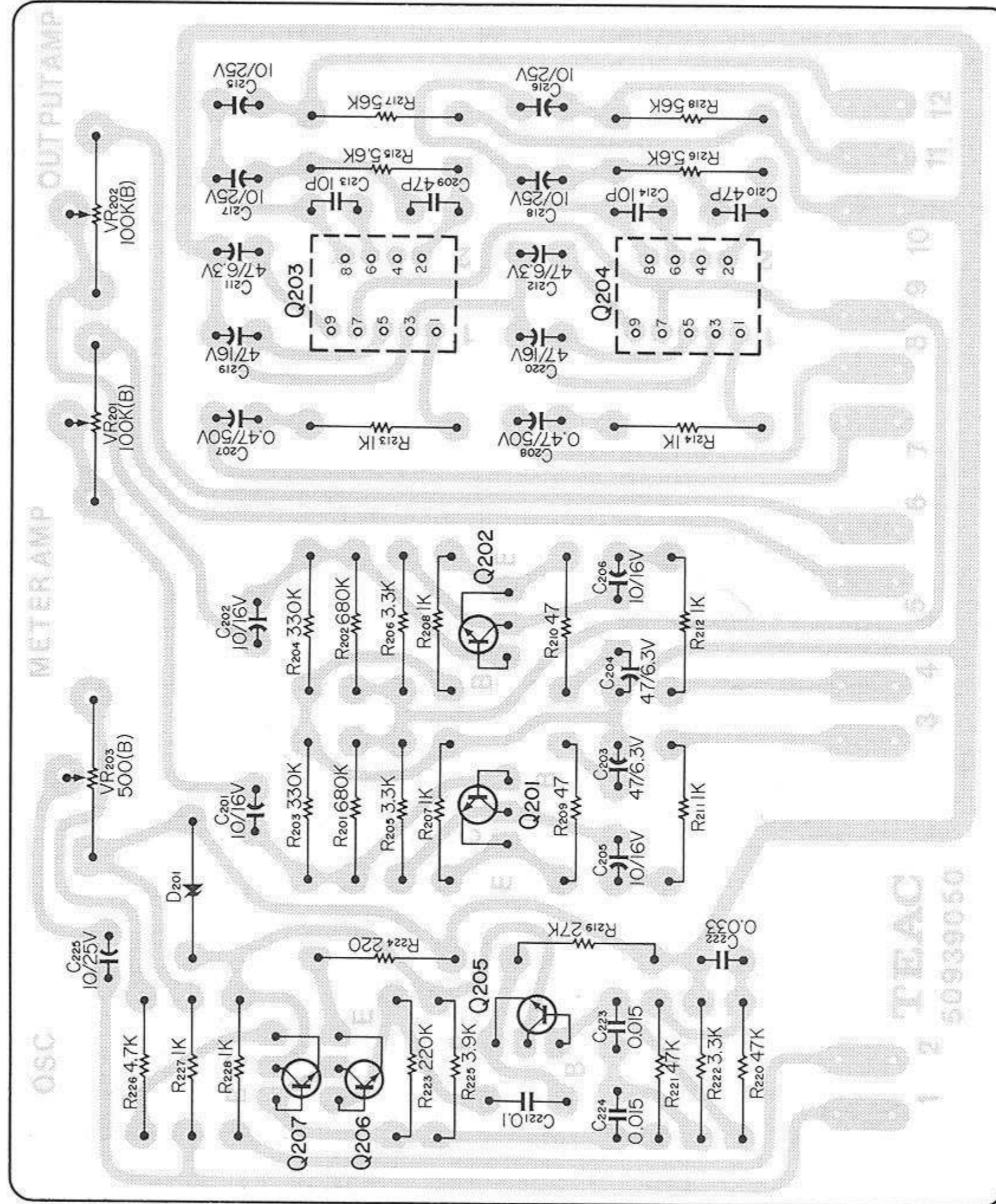

N-0463

# MIC, LINE AMPLIFIER

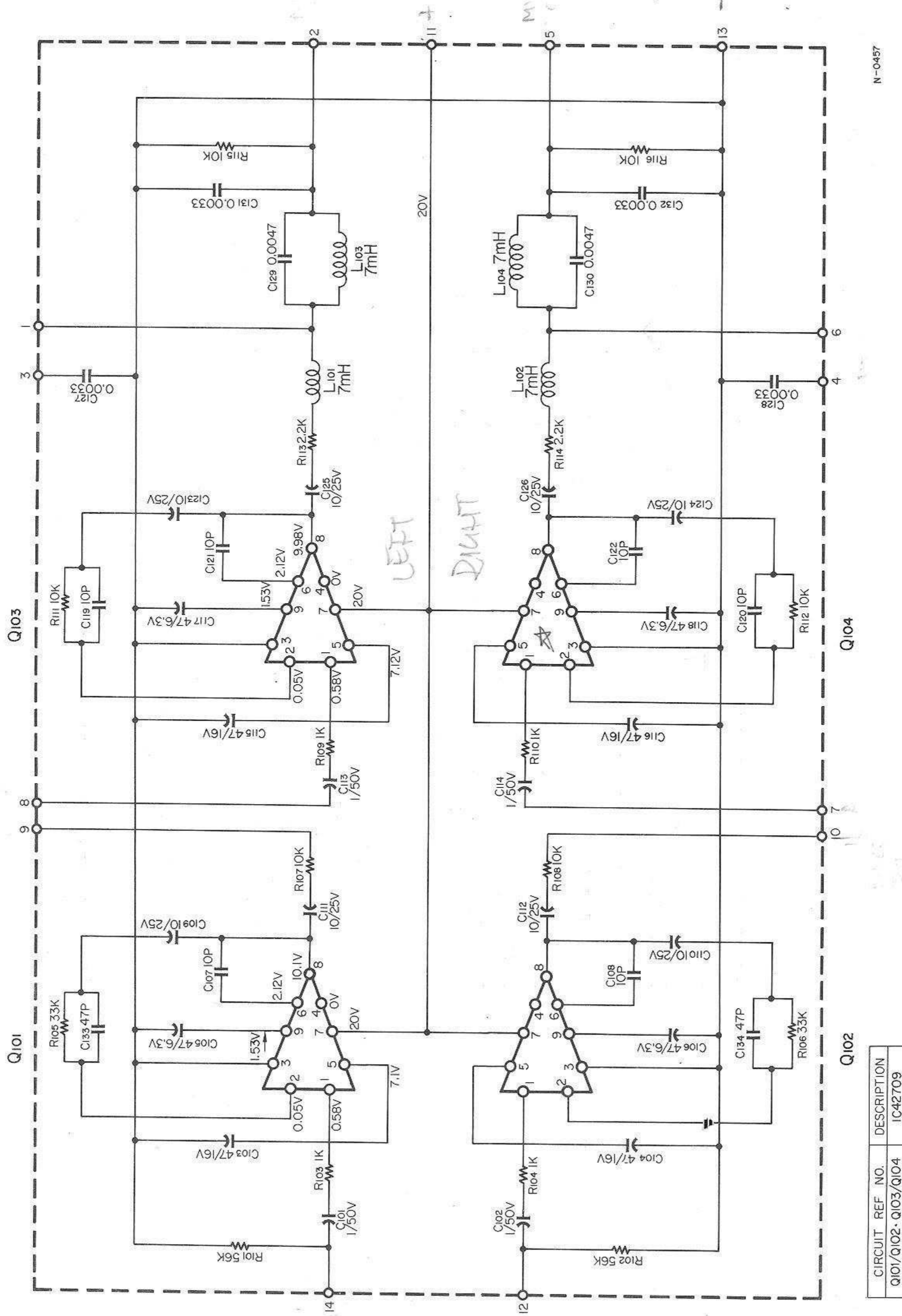

N-0457

★ REPLACED 8-3-82

# MIC, LINE AMPLIFIER

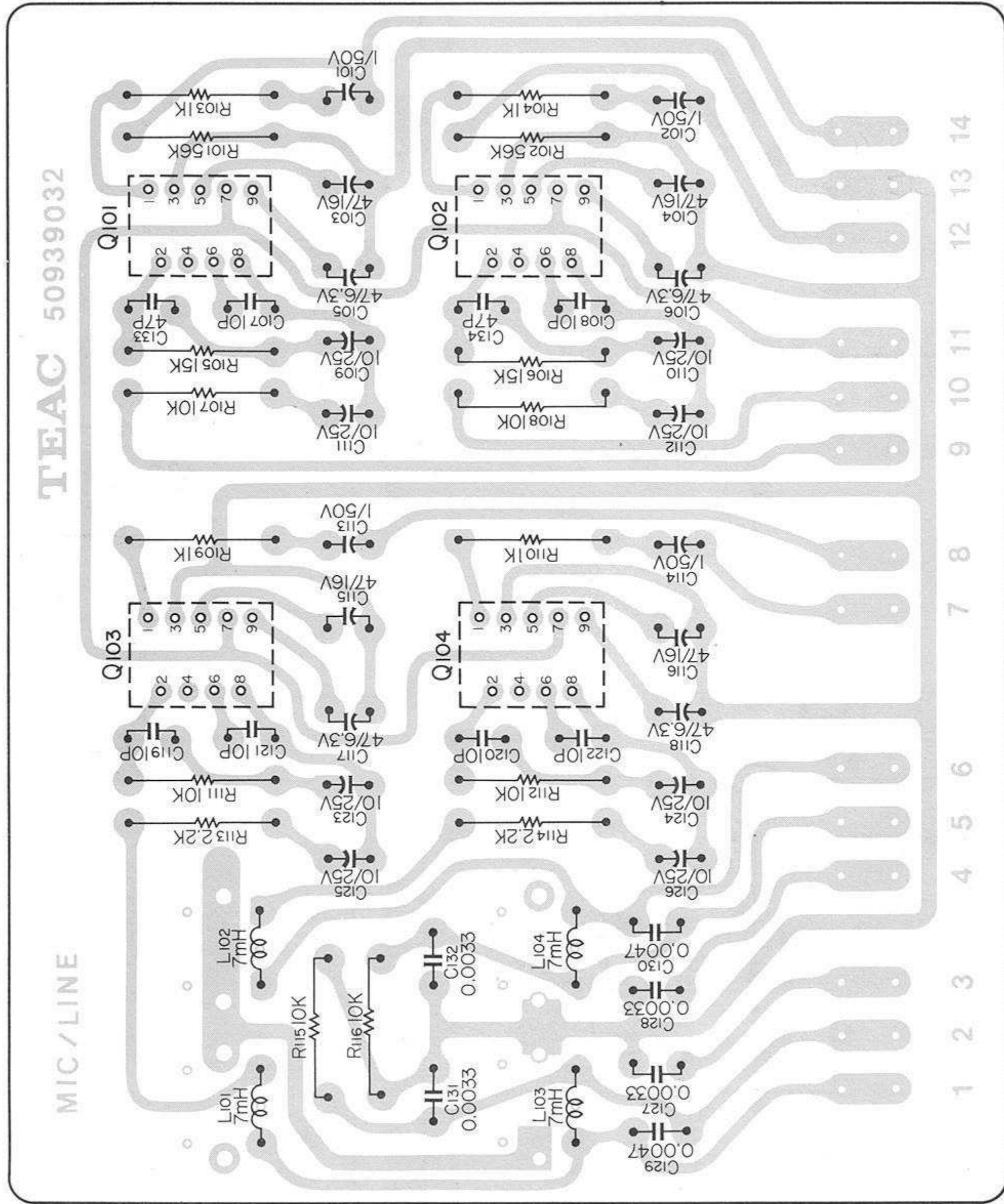

# RECORD AMPLIFIER

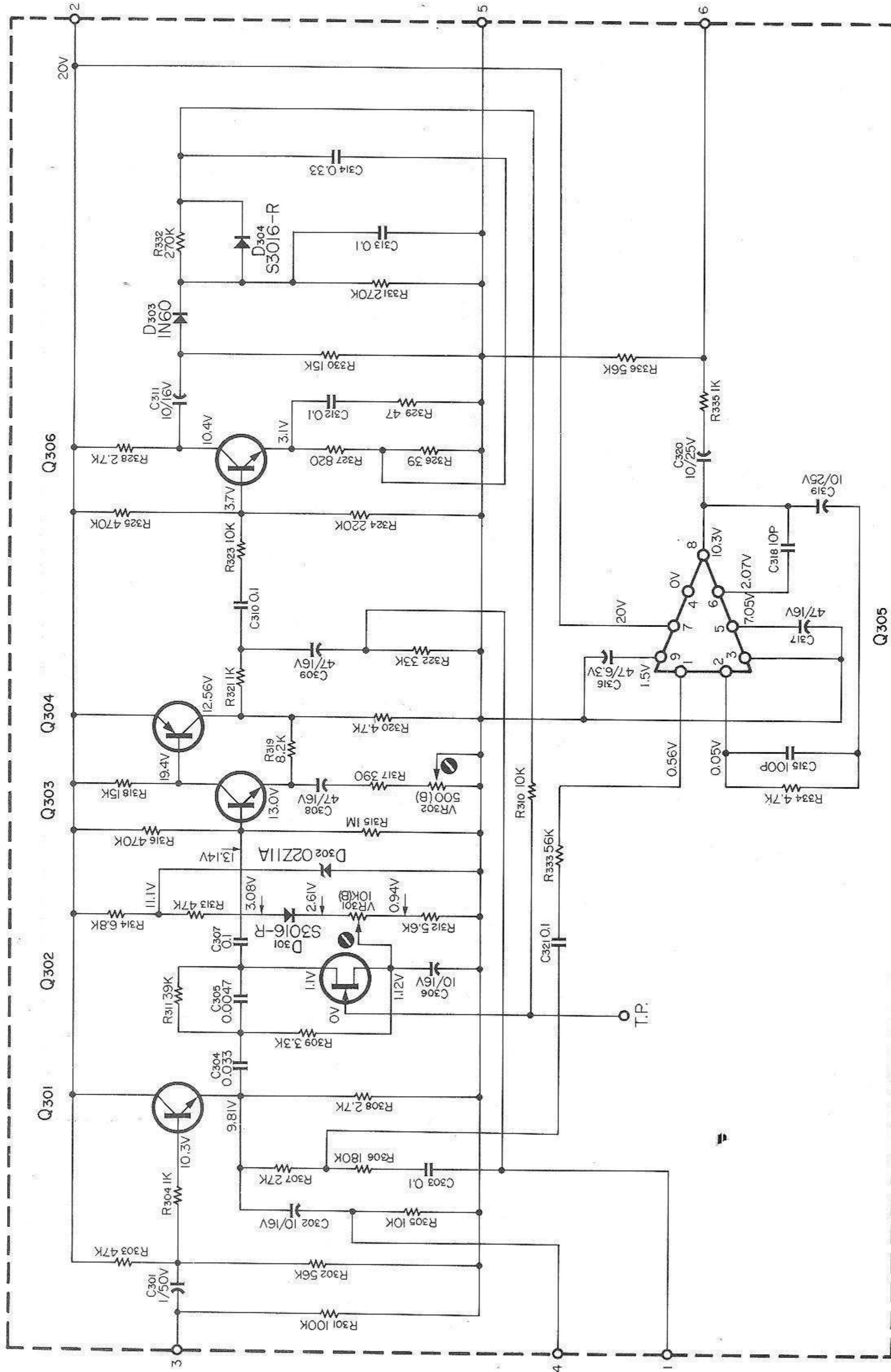

CIRCUIT REF. NO.	DESCRIPTION	CIRCUIT REF. NO.	DESCRIPTION	CIRCUIT REF. NO.	DESCRIPTION
Q301-Q303-Q306	25C733-Y	Q302	25K30-Y	Q305	1C 42709
		Q304	25A562-Y		

N-0469

# RECORD AMPLIFIER

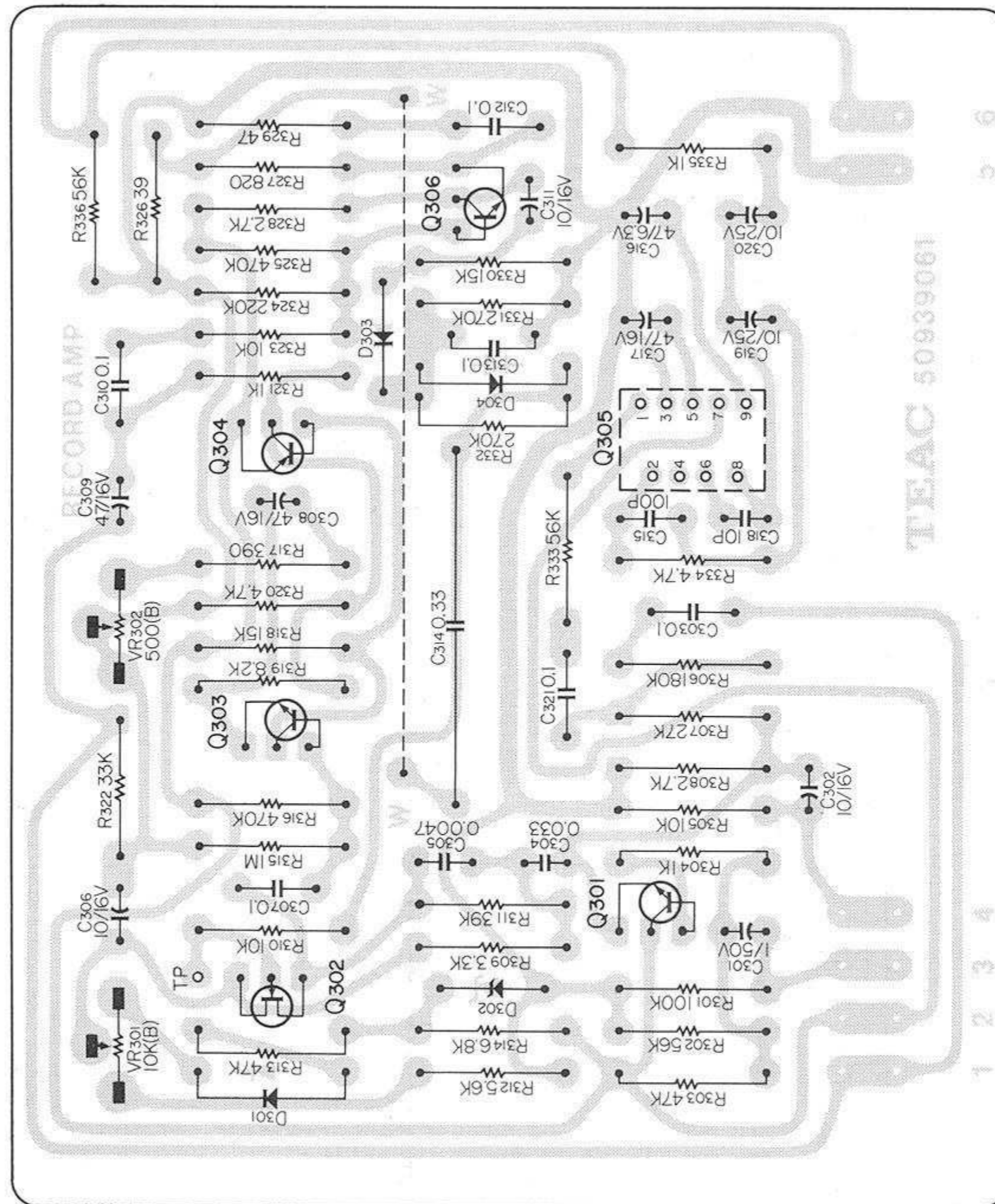



# OVERALL CIRCUIT DIAGRAM

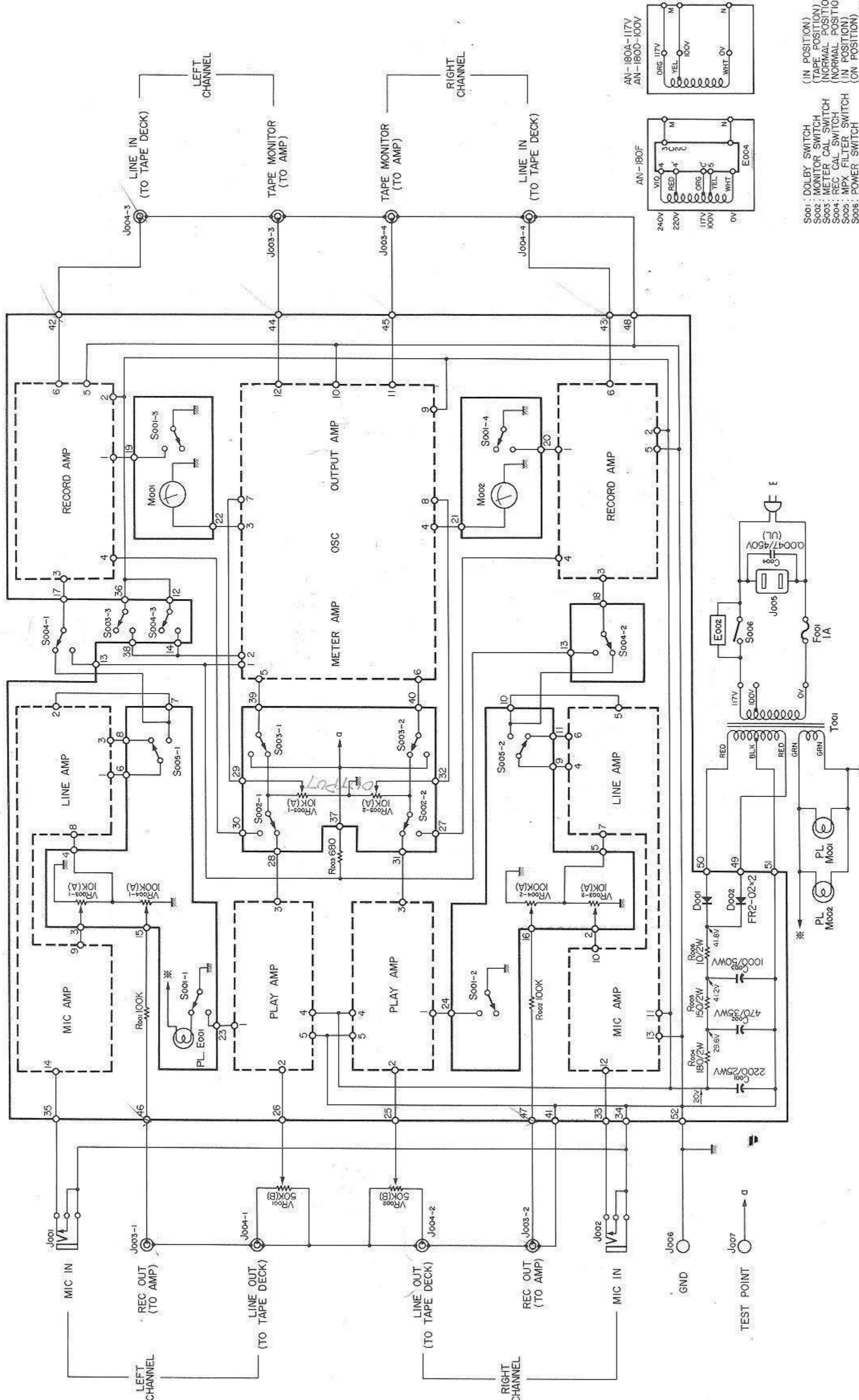

S001: DOLBY SWITCH (IN POSITION)  
S002: MONITOR SWITCH (TAPE POSITION)  
S003: REC CAL SWITCH (NORMAL POSITION)  
S004: REC CAL SWITCH (NORMAL POSITION)  
S005: MPX FILTER SWITCH (IN POSITION)  
S006: POWER SWITCH (ON POSITION)

# MAIN PC BOARD

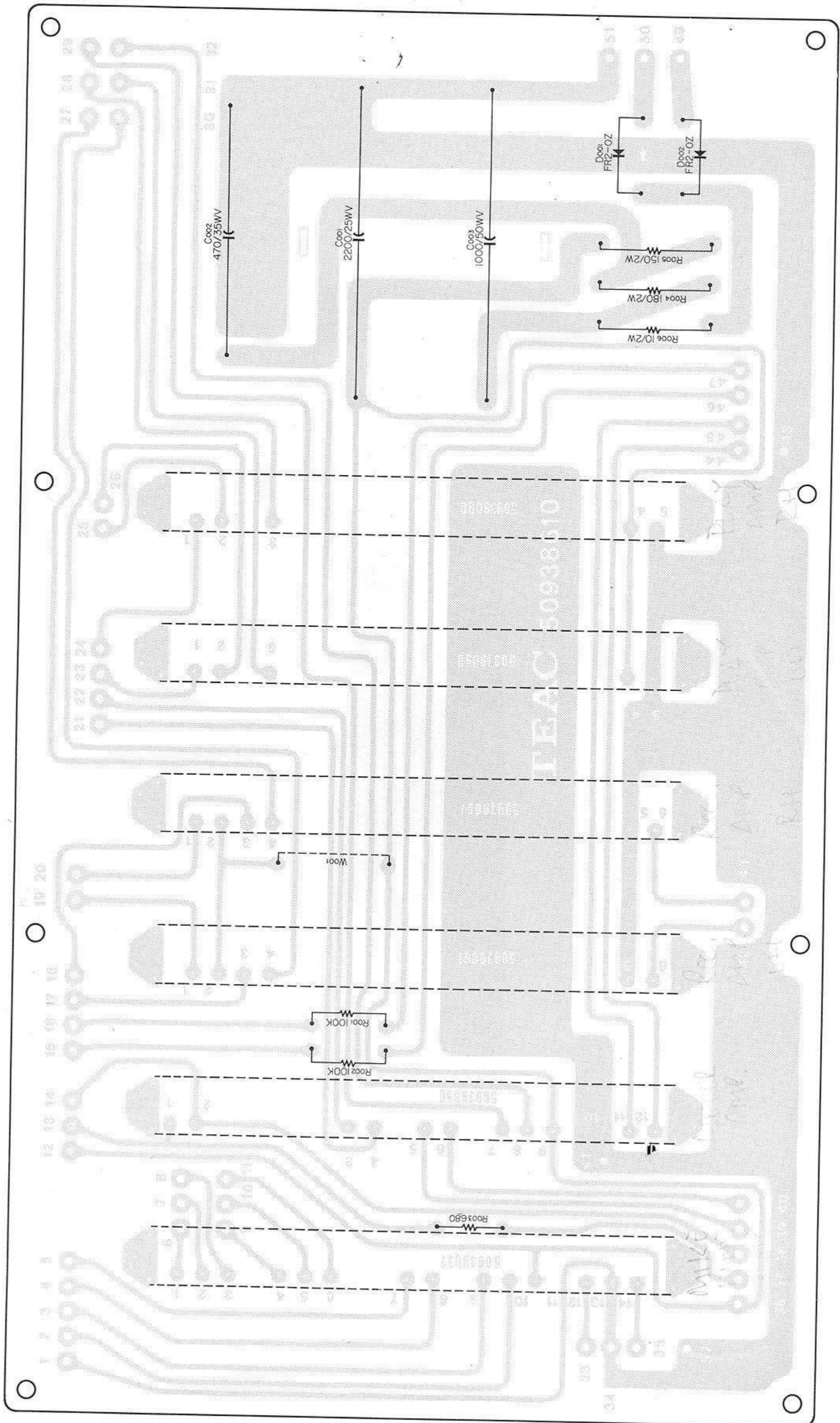

# MAIN PC BOARD

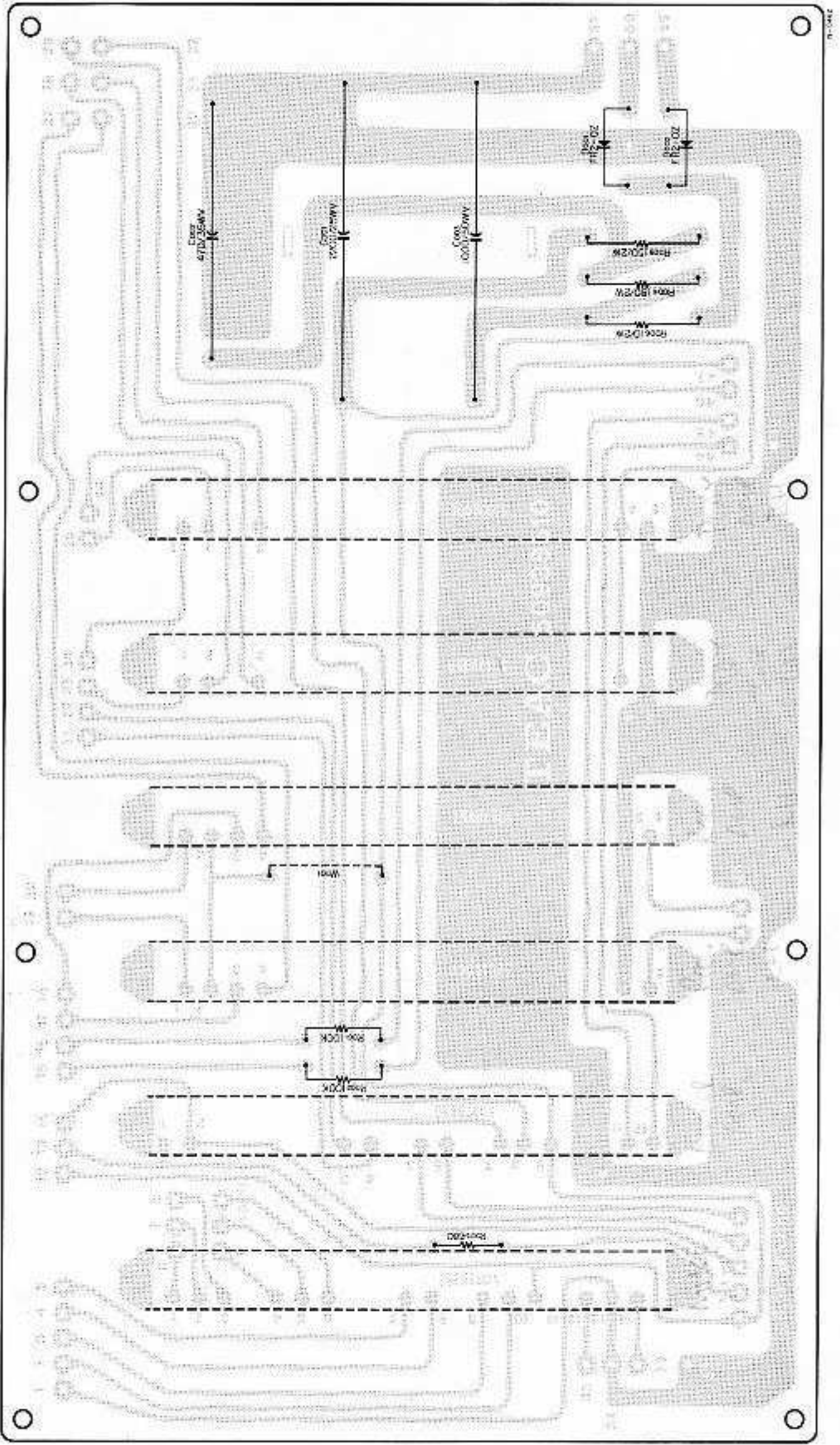

# MAIN CHASSIS

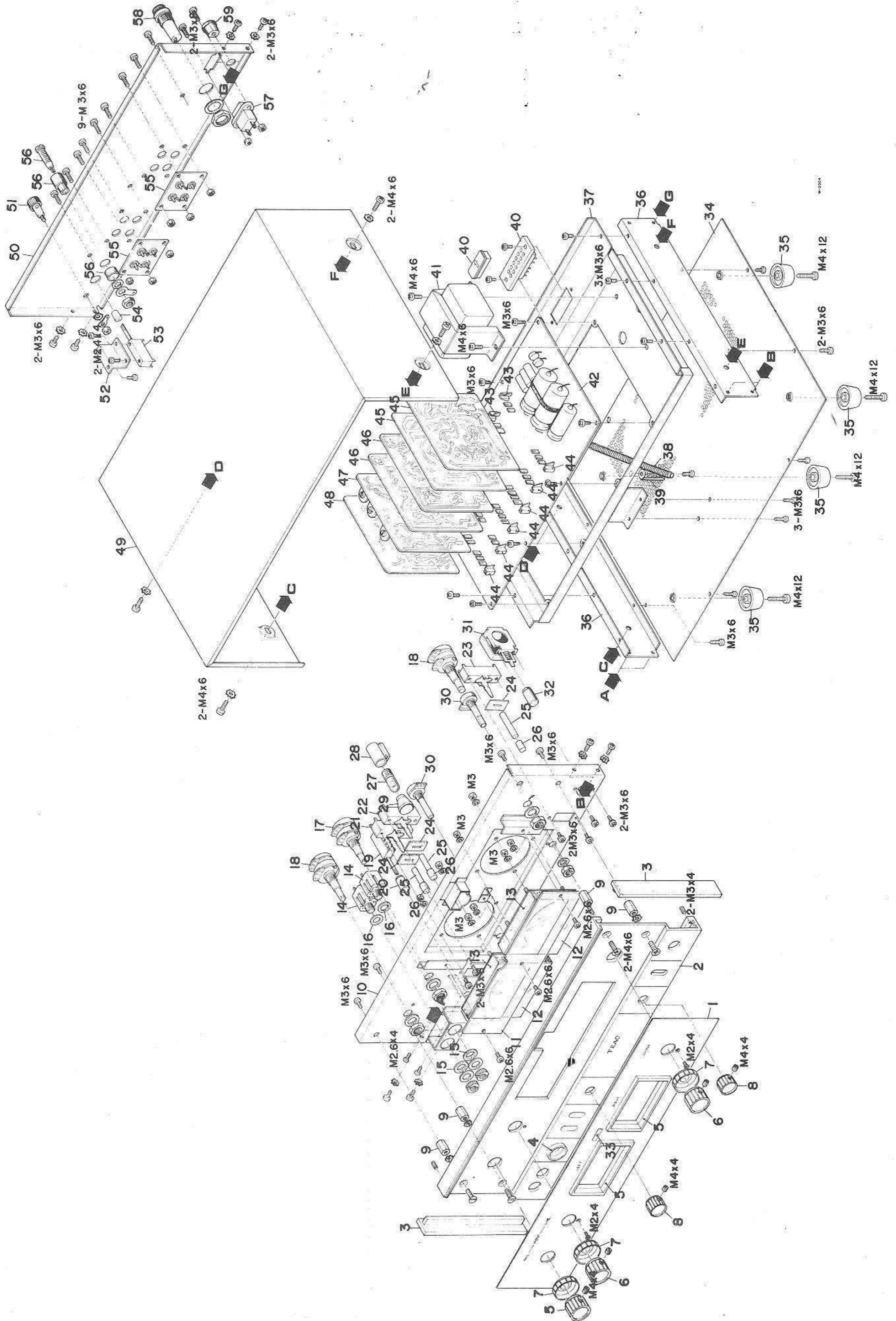

# PARTS LIST

REF. NO.	TEAC PARTS NO.	DESCRIPTION	1st	2nd	3rd	REF. NO.	TEAC PARTS NO.	DESCRIPTION	1st	2nd	3rd
1	50938720	Panel, Dress				40	50927610	Voltage Selector			
2	50938690	Panel, Front				41	50938580	Transformer			
3	50937260	Panel, Side				42	50938600	PC Board Assy, Main			
4	50938750	Knob, G, Safty Ring				43	50938970	PC Board Guide (Right)			
5	50278680	Escutcheon, Meter				44	50938980	PC Board Guide (Left)			
6	50937990	Knob, D				45	50939080	PC Board Assy, Playback Ampl.			
7	50938790	Knob, F				46	50939060	PC Board Assy, Record Ampl.			
8	50938780	Knob, E				47	50939040	PC Board Assy, Meter Ampl.			
9	50937030	Panel, Spacer				48	50939070	PC Board Assy, Mic Ampl.			
10	50938500	Chassis, Front				49	50938590	Bonnet			
11	50938510	Meter Protector				50	50938630	Panel, Back			
12	50581310	Meter, Level				51	50454071	Terminal, GND			
13	50939110	Band, Meter				52	50938930	Switch Mount Bracket			
14	50430240	Jack, 1P				53	50938950	Switch, Push			
15	50272620	Washer, B				54	50938760	Knob, Push Switch			
16	50230560	Washer				55	50430190	Jack, Pin, US 4P			
17	50938530	Control, Line				56	50938650	Pinchip			
18	50938520	Control, Mic				57	50924510	AC Outlet			
19	50938940	Switch, Push				58	50412130	Fuse Holder			
20	50938800	Knob, G				59	50271670	Grommet			
21	50936690	Switch, Lever									
22	50937580	Switch, Lever									
23	50936680	Switch, Lever									
24	50937220	Sheet, Lever Switch Protector									
25	50937110	Lever, Knob									
26	50937070	Knob, Lever Escutcheon									
27	50414131	Lamp, Pilot									
28	50415030	Socket, Lamp									
29		Cover Pilot Lamp									
30	50938540	Control, Playback									
31	50926280	Switch, Power									
32	50937270	Knob, Power Switch									
33	50938770	Indicator									
34	50938810	Cover, Bottom									
35	50283830	Mount Foot									
36	50938570	Chassis, Side									
37	50938560	Chassis, Main									
38	50939100	Shield Pipe									
39	50937240	Cord, Clamp									

# AN-180 NOISE REDUCTION UNIT EXPLODED VIEW AND PARTS LIST

# TEAC MANUAL CHANGE SHEET

**APPLICABLE CHASSIS NO.**

AN-180 SERIAL NO.6201 AND AFTER  
**LOCATION IN SERVICE MANUAL**  
 EXPLODED VIEW AND PARTS LIST

**MODELS** AN-180

**REVISION 1**

Pilot light assy has been changed from screw base to bayonet type to preclude loosening of bulb during transportation.

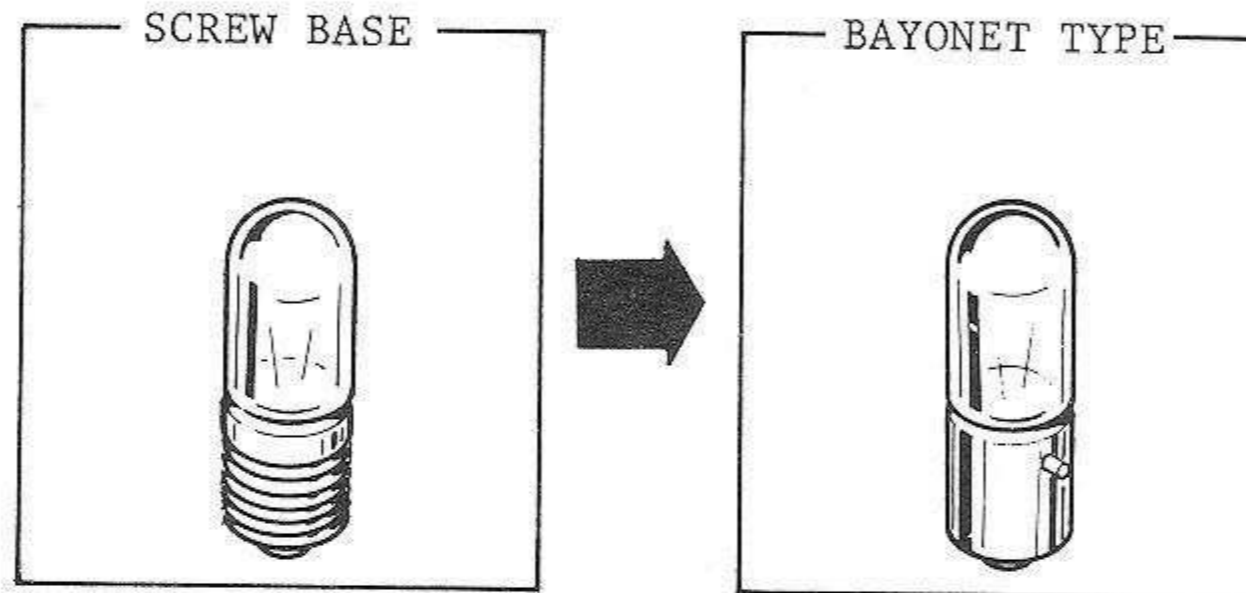

M-0315

REF.NO.	DESCRIPTION	TEAC PARTS NO.	
		BEFORE	AFTER
27	SOCKET, LAMP	50415030	50415250
28	PILOT LAMP	50414131	50414510
	PILOT LAMP (UL)	-----	50414580

**REVISION 2**

Power switch filter assembly has been replaced with an improved type to preclude current leakage.

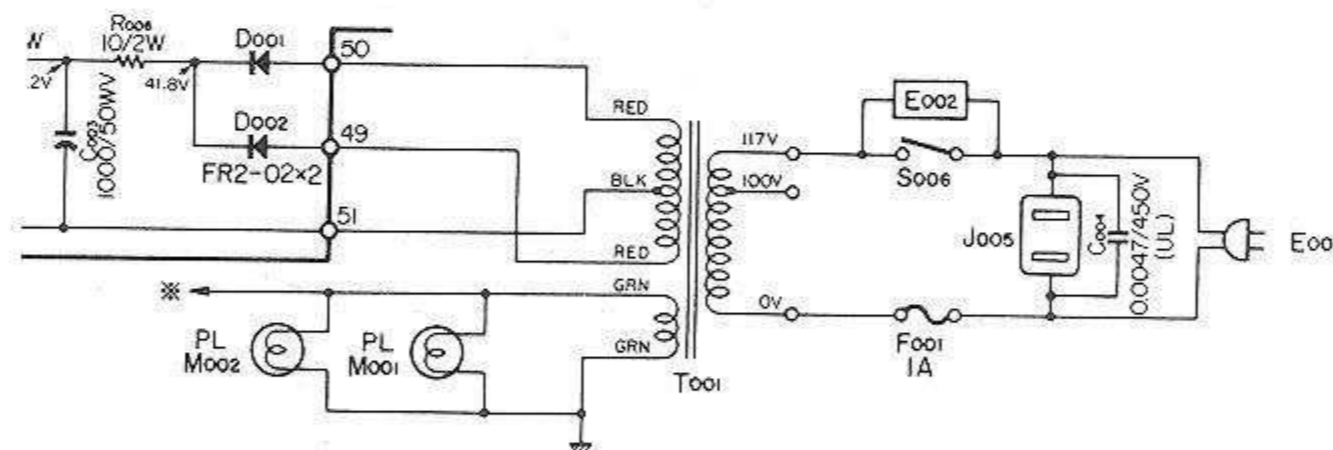

POWER SUPPLY CIRCUIT -PARTIAL-

CIRCUIT REF.NO.	DESCRIPTION	TEAC PARTS NO.	
		BEFORE	AFTER
E002	SPARK-KILLER	50529070	50529060

T-455